

# 660 Series Modularized UPS

## User Manual



## Preface

Thank you so much for using our company's products.

Our company is engaged in developing and manufacturing products of uninterrupted power system which is a kind of power product with high quality and can meet various performance requirements.

### **Note:**

This manual contains instruction of mounting, application, and operation of UPS. It shall read this manual carefully before mounting the system and it shall not take any operations on UPS before finishing reading all safety instruction and operation instruction. This manual contains significant information, please obey all warnings and operation instructions stated by the manual and machine, and the manual shall be kept well.

### **Safety**

The uninterrupted power system must be grounded before operation.

Battery shall be replaced by qualified maintenance personal. The battery is toxic waste .According to laws, so wasted battery shall be recovered by its classification in accordance with requirement of environmental protection.

### **Warning**

Selling of this product is only for partner who has general information on UPS products. It is necessary to know some other mounting requirements or measures to prevent accident.

Any content of the manual shall not be modified without allowance of manufacturer and any offenders must be investigated. Our company reserves the right of final interpretation.

# CATALOG

<b>CHAPTER 1: BRIEF INTRODUCTION OF 660 SERIES MODULARIZED UPS SYSTEM .....</b>	<b>1</b>
<b>1.1 Brief Introduction .....</b>	<b>1</b>
<b>1.2 System Structure.....</b>	<b>2</b>
<b>1.3 Operating Mode .....</b>	<b>4</b>
<b>1.4 Functions and Characteristics.....</b>	<b>6</b>
<b>CHAPTER 2: INSTALLATION OF 660 MODULARIZED UPS .....</b>	<b>8</b>
<b>2.1 Environmental Selection .....</b>	<b>8</b>
<b>2.2 Venue Layout .....</b>	<b>8</b>
<b>2.3 Unloading and Unpacking .....</b>	<b>9</b>
<b>2.4 Cable Selection and Connection .....</b>	<b>12</b>
<b>2.5 Battery Connection.....</b>	<b>18</b>
<b>2.6 Installation of Modules .....</b>	<b>19</b>
<b>CHAPTER 3: 660 MODULARIZED UPS OPERATIONS.....</b>	<b>20</b>
<b>3.1 Introduction of Monitoring Module .....</b>	<b>20</b>
<b>3.2 Startup operation .....</b>	<b>22</b>
<b>3.3 Operation for Turning Off.....</b>	<b>29</b>
<b>3.4 Operation for Emergency Power Off.....</b>	<b>30</b>
<b>3.5 Operation for Maintenance Bypass .....</b>	<b>31</b>
<b>3.6 Enquiry Operation .....</b>	<b>32</b>
<b>3.7 Operations for User Set.....</b>	<b>40</b>
<b>CHAPTER 4: UPS REPAIRING AND MAINTENANCE .....</b>	<b>47</b>
<b>4.1 UPS Repairing and Maintenance.....</b>	<b>47</b>
<b>4.2 Trouble shooting.....</b>	<b>48</b>
<b>4.3 Maintenance Assurance .....</b>	<b>52</b>
<b>4.4 Technical Specifications.....</b>	<b>52</b>
<b>APPENDIX 1: LAMP SIGNAL REFERENCE LIST.....</b>	<b>54</b>
<b>APPENDIX 2: PORT OF COMMUNICATION INTERFACE .....</b>	<b>55</b>

# Chapter 1: Brief Introduction of 660 series Modularized UPS System

## 1.1 Brief Introduction

660 series UPS is high-frequency modularized UPS power with three-inlet and three-outlet offered by our company, full digital control technology is applied for the product. The modularization design is used for the overall unit, including power module, charger module, and monitoring module, and all modules support hot-plugging operation. The modularization design is used for all modules of the overall unit which ensures compatibility of layout and improves reliability of overall unit; full isolation of damaged components and air flue is achieved inside the power module and charger module which improves reliability of overall unit further; in addition, advanced “N+X” wireless parallel connection redundant technique is used for the overall unit which reduces probability UPS single point fault farthest so that the reliability design of overall unit is trending to be perfect.

660 modularized UPS family contain 80KVA、160KVA、200KVA and 400KVA four kinds of module. And the power module provides 20KVA/16KW and 20KVA/20KW two choices to meet the needs of various power section consumer.

Table 1.1 the maximum power configuration of 660 families

Rack type	80KVA	160KVA	200KVA	400KVA
Max module amount	4	8	10	20
20KVA/16KW power module output capacity	80KVA/64KW	160KVA/128KW	200KVA/160KW	400KVA/320KW
20KVA/20KW power module output capacity	80KVA/80KW	120KVA/120KW (6 modules at most)	200KVA/200KW	400KVA/400KW

Schematic diagram of overall unit is shown in figure 1.1:

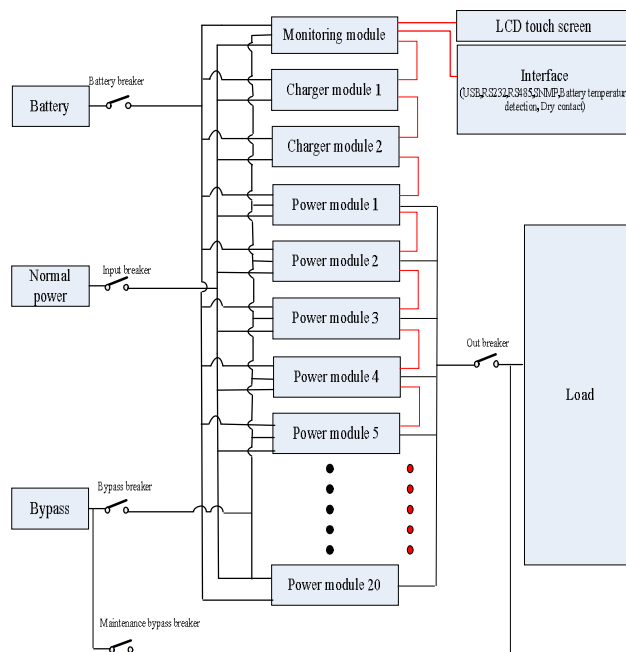

Figure 1.1 Schematic Diagram of 660 Overall Unit Product

## 1.2 System Structure

Components of the system mainly include: monitoring module, charger module, power module, lightning protection breaker, lightning protection device and communication port. Besides, the 80KVA and 160KVA module contain input breaker, bypass breaker, output breaker, maintenance bypass breaker, etc. The system structure chart is shown in figure 1.2:

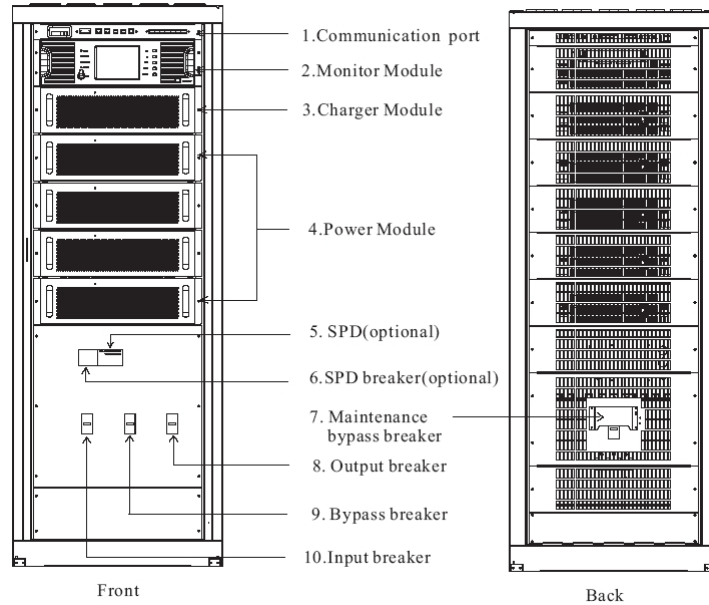

Figure 1.2 System Structure Chart of 80KVA Module

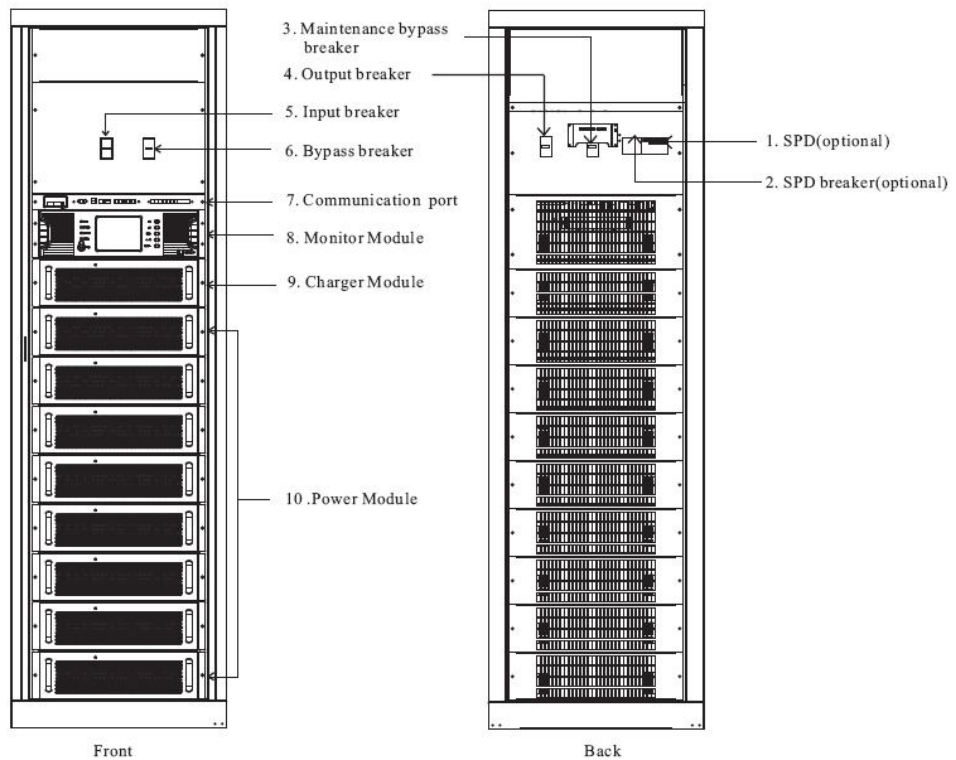

Figure 1.3 System Structure Chart of 160KVA Module

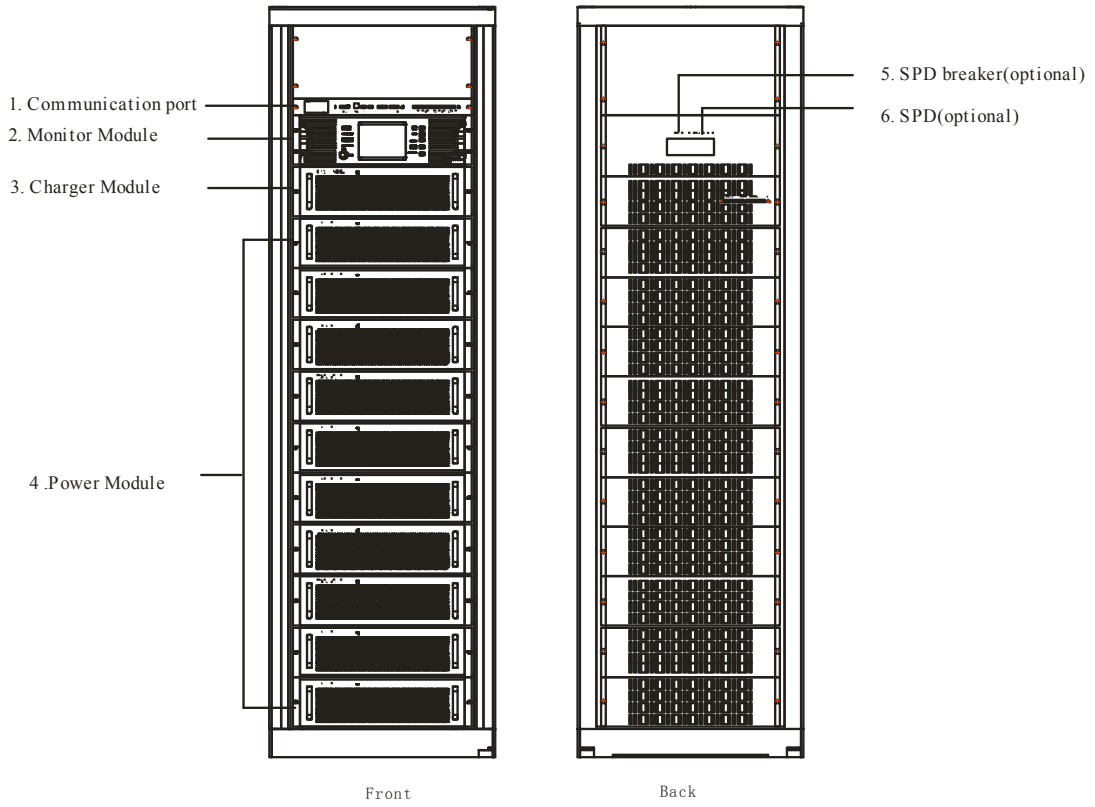

Figure 1.4 System Structure Chart of 200KVA Module

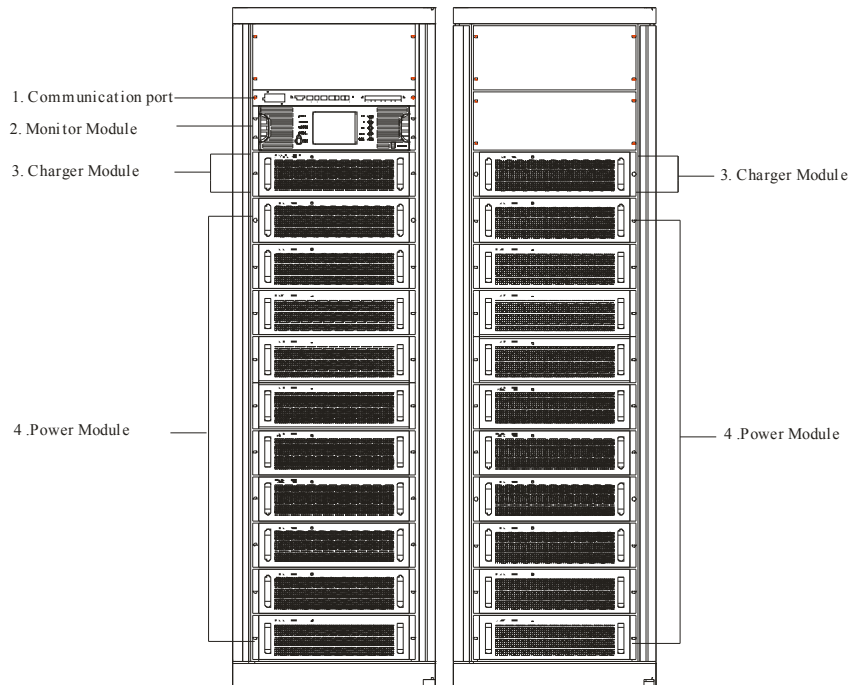

Figure 1.5 System Structure Chart of 400KVA Module (front)

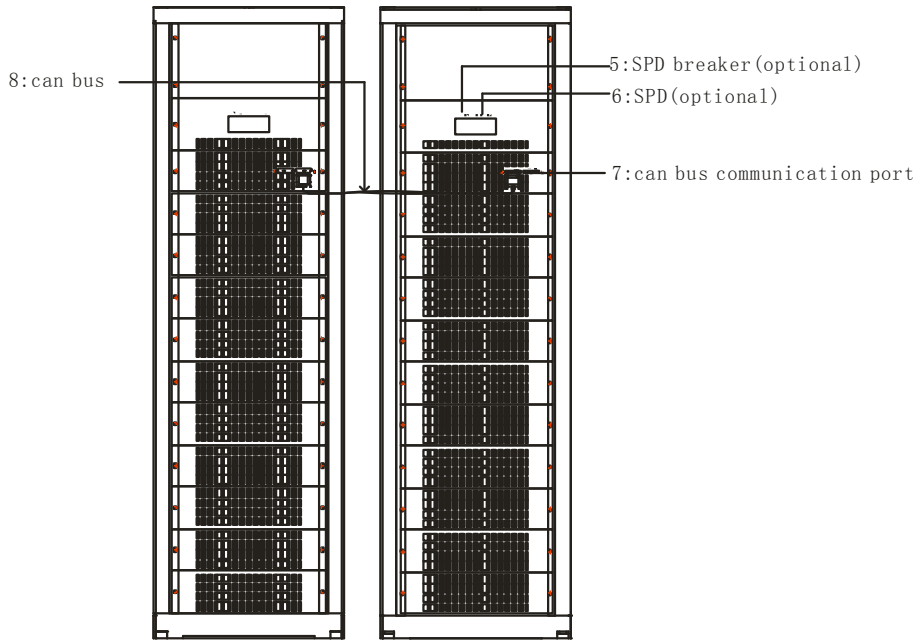

Figure 1.6 System Structure Chart of 400KVA Module (back)

### 1.3 Operating Mode

660 UPS is online double-conversion UPS, its working modes are as followings:

- Mains mode(on line mode)
- Battery mode
- Bypass mode
- Maintenance mode (manual bypass)
- Frequency converter mode

#### 1.3.1 Mains Mode

The working mode that mains supplies the rectifier circuit in the UPS power module with AC power and AC power to the inverter through corrected PFC power factor, and then gives continuous and uninterrupted AC power to the load through inverter circuit is called mains mode. The charger module can be started under mains mode and the battery can be charged by mains through charger module.

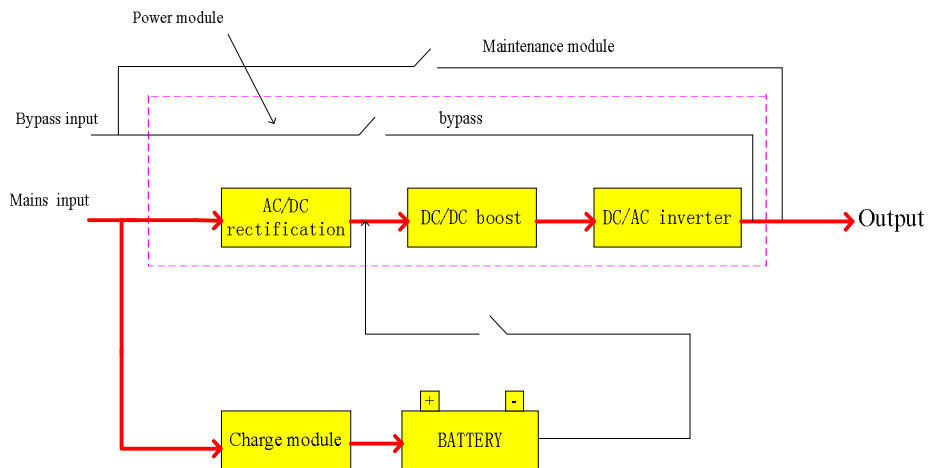

Figure 1.7 Working Process Chart for Single Module under Line module

### 1.3.2 Battery Mode

Battery power is boosted through battery booster circuit, and then supplied to load through inverter circuit is called battery mode. When main power fault occurs, the system will switch to battery mode automatically and power supply for load is not interrupted. When main power recovers, the system will switch to main power mode automatically without any manual operation and power supply for load is not interrupted. Switching time of main power mode and battery mode is 0ms.

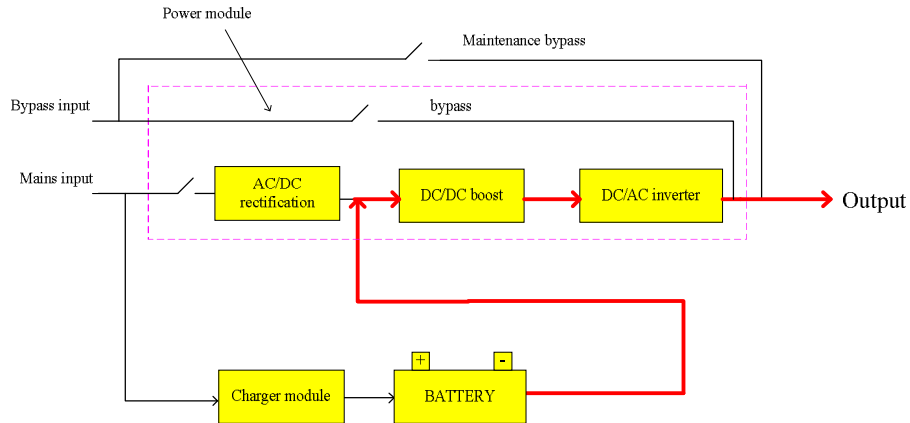

Figure 1.8 Working Process Chart for Single Module under Battery Mode

### 1.3.3 Bypass Mode

If fault such as inverter circuit fault and inverter circuit overload, or switching to bypass mode by hand occurs, the power module will switch the load from side of inverter circuit to side of bypass and power supply for the load is not interrupted. Charger module can be started under bypass mode, the battery can be charged by mains through charger module.

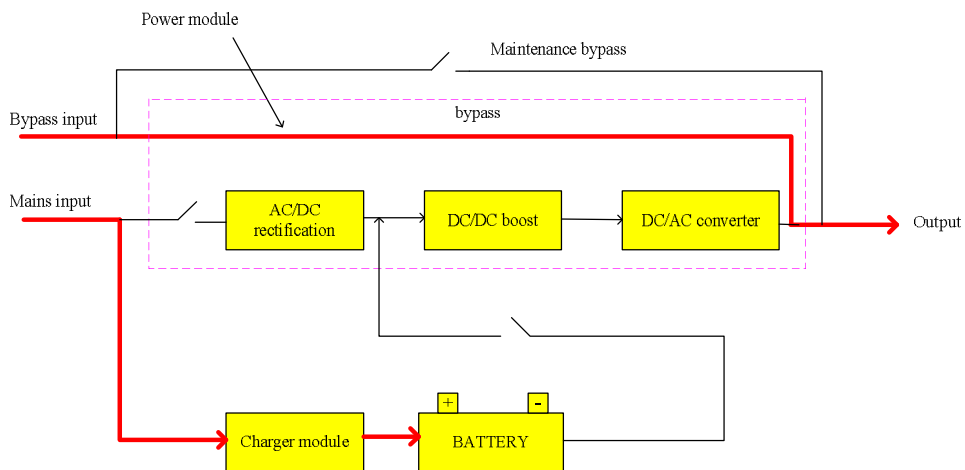

Figure 1.9 Working Process Chart for Single Module under Bypass Mode



### 1.3.4 Maintenance Mode (Manual Bypass)

If it needs to maintain or repair the UPS, it can close the manual bypass switch to switch the UPS to the side of maintenance bypass and the power supply for load is not interrupted. In that case, the mains will not pass the internal components of machine but connect the input terminal and output terminal directly so that we can maintain or repair the UPS.

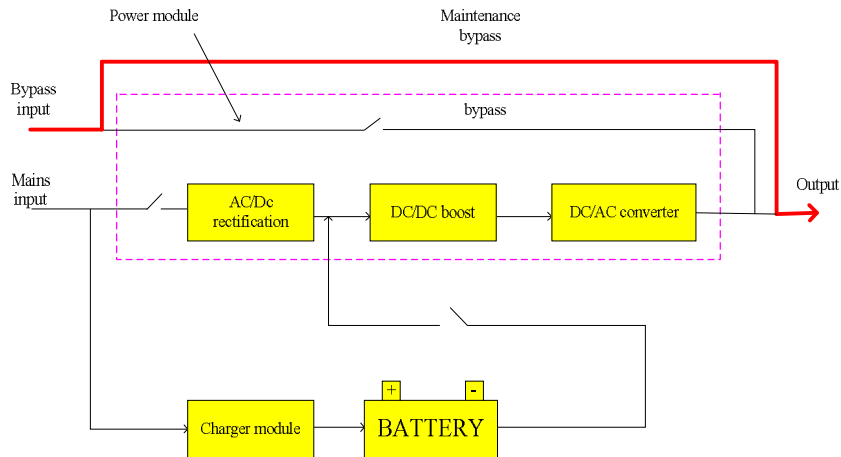

Figure 1.10 Working Process Chart under Maintenance Bypass Mode

### 1.3.5 Frequency Transformer Mode

UPS can be set to be frequency transformer mode which can provide stable frequency output of 50 Hz or 60 Hz. Input frequency range of mains is 40 Hz ~ 70 Hz. UPS will output the set output frequency and the bypass mode is ineffective under frequency transformer mode. When mains is abnormal, the system will switch to battery mode automatically and still output with the setting output frequency.

## 1.4 Functions and Characteristics

- ❖ DSP full digital control technology;
- ❖ Pure online double-conversion framework, strong load capability;
- ❖ All modules support hot-plugging technology;
- ❖ Internal integrated power system of cabinet is convenient for mounting and can save user's investment;
- ❖ Input power factor is as high as more than 0.99, low harmonic current, environmental protection, high-efficient, and energy saving;
- ❖ Wide input voltage range, 50/60 Hz power system self-adoption suitable for all grid under any circumstance;
- ❖ Support frequency mode of 50 Hz input / 60 Hz output and 60 Hz input / 50 Hz output which can meet special requirements of user;
- ❖ "N+X" wireless parallel connection redundant technique can set number of parallel machines by LCD screen;
- ❖ Parallel machines share the battery group which can save cell investment from user;

- ❖ The power module capability is 20 KVA / 16 KW or 20KVA / 20KW. According to the difference of modules, the overall unit can be extended to 80 KVA / 64 KW or 80 KVA / 80 KW , 160KVA/128KW,200KVA/160KW or 200KVA/200KW , 400KVA/320KW or 400KVA/400KW,and the maximum charging current is 120A(4 charger modules);
- ❖ A 16-way output power distribution module and a built-in battery pack module are available to choose, selecting module can realize hot plug;
- ❖ Flexible charging parameter setting and battery configuration, charging current can be set from 0 - 120A, and pieces of battery can be 32 - 40 (32、34、36、38、40);
- ❖ Advanced battery intelligent management technology (three-stage intelligent charging, compensation factor of battery temperature, etc.) can prolong working life of battery effectively;
- ❖ Support cold start of battery and automatic start of normal power which can meet user' s application requirements;
- ❖ Easily damaged components are completely isolated with air flue which can improve reliability of the system effectively;
- ❖ Easily damaged components can be changed in module level, field replacement is fast and convenient and module cost is low;
- ❖ Front operation combining with upper and lower line is convenient for connection;
- ❖ Perfect hardware and software protection function (level C lightning protection, breaker, Fuse, hardware protection, and software protection), super self diagnosis, and rich historic record enquiry;
- ❖ 5.7 inch LCD touch wide screen display, friend human-computer interface;
- ❖ Many communication ports, including RS232, RS485, USB, dry contact card and SNMP card.

## Chapter 2: Installation of 660 Modularized UPS

### 2.1 Environmental Selection

- ✧ Placed location must be stable;
- ✧ Enough ventilation space must be left between all surfaces of UPS machine and walls;
- ✧ Be far away from hot source and corrosive materials, avoid the sunshine;
- ✧ Keep normal working temperature and elevation height (working temperature: 0°C ~ 40°C, it needs to be applied by derating if elevation height exceeds 1500m);
- ✧ Keep clean working environment, avoid environment with moisture, flammable gas, flammable liquid, or corrosive material;
- ✧ Weight capability of floor to machine and battery group shall be considered before mounting.

### 2.2 Venue Layout

It needs to put the expansion bolts into foundation when placing the UPS in order to ensure stability of UPS, and then tighten the expansion bolts after the cabinet is placed stably. Its locating data is shown in figure 2.1 (unit: mm):

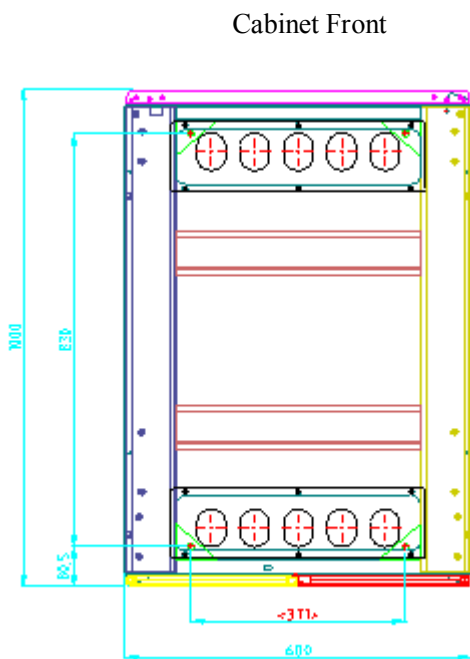

Figure 2.1 Bedplate Chart of 80KVA Module Cabinet

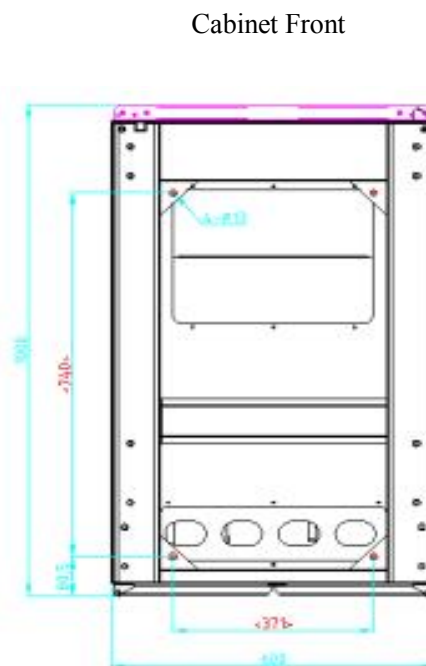

Figure 2.2 Bedplate Chart of 160KVA、  
200KVA、 400KVA Module Cabinet

Location of the UPS shall be proper in order to ensure safety application of UPS. It shall be placed in place with clean environment without moisture, flammable gas, flammable liquid, corrosive material or sunshine. User can put it on assigned location with assistant of human force or equipment and shall pay attention to spaces between UPS and surrounding things when mounting so that it is helpful for ventilation and heat dissipation. Minimum space is shown in figure 2.3 (unit: mm):

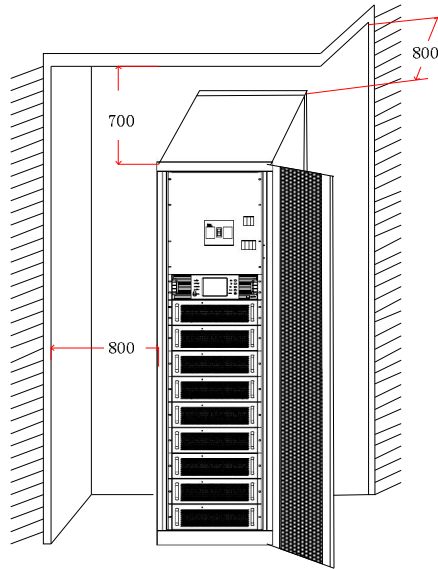

Figure 2.3 Scale Map of Mounting Field of Cabinet

**Tips: do not insert any object into air vent or other vent to ensure good ventilation environment so that it is benefit for ventilation and heat dissipation.**

### 2.3 Unloading and Unpacking

User shall check the package to confirm it is undamaged after receiving the product; then open the package to check whether the equipment is undamaged, and please contact the carrier at once if it is damaged.

#### 1. Open the system packing

Open the wood box firstly, and its methods are as follows:

1) Put the wood box vertically;

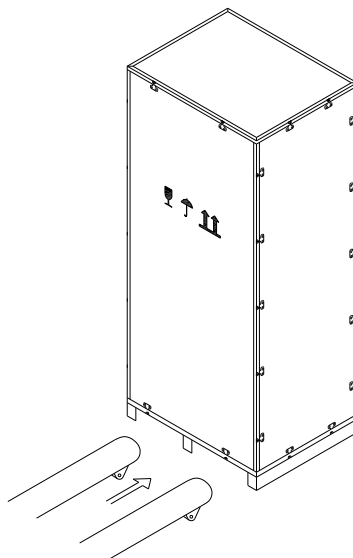

Figure 2.4 Wood Box Placement

**Tips: it shall pay attention to that wood legs supporting the box shall be down when placing the wood box, otherwise it is inconvenient for dismantling of wood box and placement of system.**

2) Open the top plate of wood box and then take out the pearl cotton;

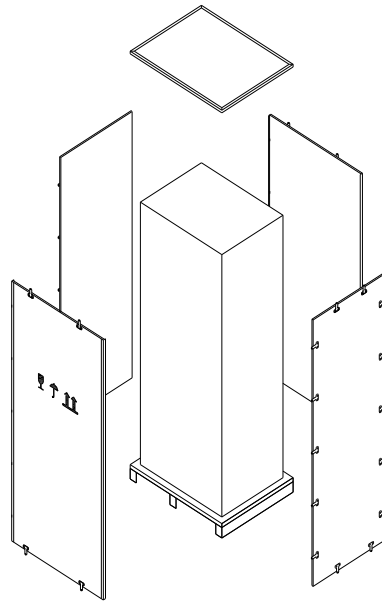

Figure 2.5 Unseal the Wood Box

**Tips: use slotted screw driver and pincher to open the top plate of wood box with steel edges and then open the side plates. Be careful for no scratch of the product.**

3) Unseal side plates of wood box and then take out the pearl cotton.

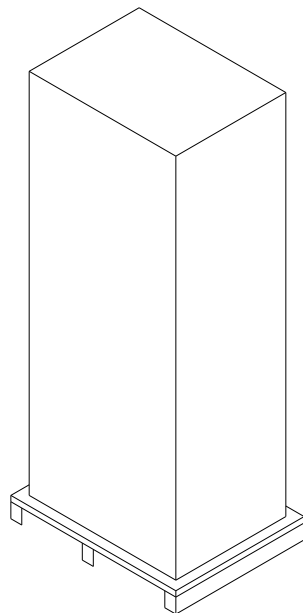

Figure 2.6 Unsealed Cabinet

**Tips: it can place the cabinet to mounting location by removing crews connecting the cabinet and wood supports after unsealing. It shall be careful when unsealing to prevent scratch for the machine body.**

Check whether the qualified certificate, instruction book, CD disk, and keys for front and back doors are complete or not after opening the wood box.

2. Open the module packing  
Open procedures of module packing are as follows:
  - 1) Place the packing box in stable;

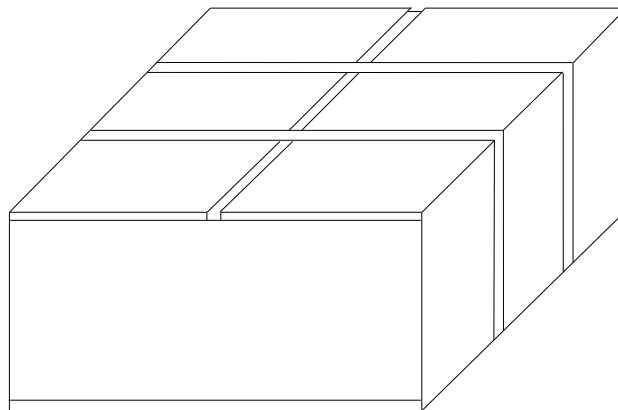

Figure 2.7 Outer Packing of Module

- 2) Cut off the plastic belts, remove the scotch tape, and then open the paper box;

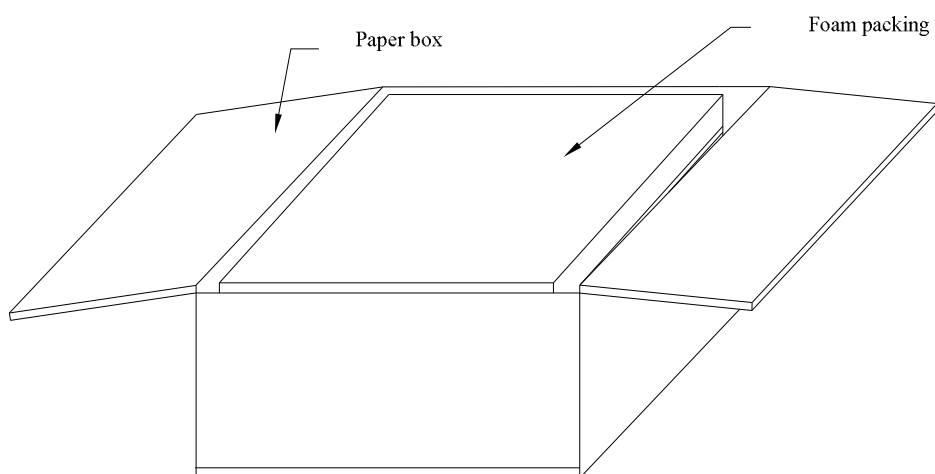

Figure 2.8 Unseal the Module Packing

3) Remove cover of foam packing, the equipment with plastic packing will appear;

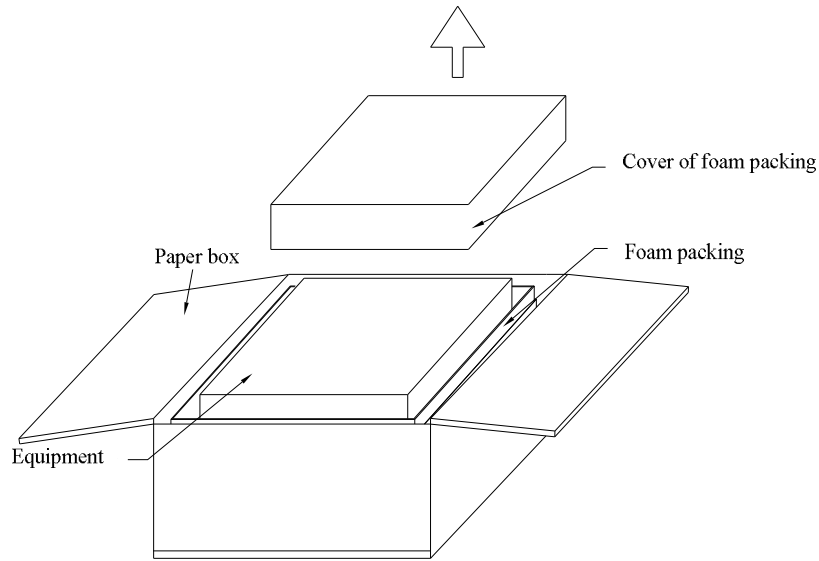

Figure 2.9 Taking out of Module

4) Finally, take out the equipment with plastic packing, and then remove the plastic packing.

**Tips: appendixes along with cabinet and modules shall be kept well, especial that the manual and CD disk contain much safety instruction, please do not operate the equipment before reading the whole safe operation instruction. All warnings and operations shown by machine and manual shall be obeyed strictly.**

## 2.4 Cable Selection and Connection

### 2.4.1 Cable selection

When selecting connecting cable for the system, it is suggested to select wire diameter of cable according to maximum power configuration of 660 system and complying local connection rules and environmental condition (temperature and physical support media). The cable shall be selected according to maximum steady-state alternating and direct currents of 660, and its selection conditions are listed in table 2.1:

Table 2.1 Cable Current Table

UPS rated power	Input current when it is full load and charger module output maximum power	Output current when it is full load	Current of 32 pieces batteries
80KVA/64KW	176A	121A	215A
80KVA/80KW	200A	152A	269A
160KVA/128KW	250A	242A	430A
200KVA/160KW	391A	303A	537A
200KVA/200KW	480A	379A	672A
400KVA/320KW	749A	606A	1074A
400KVA/400KW	928A	758A	1344A

## 2.4.2 Cable connection

660 modularized ups equipped with power distribution system in 80KVA and 160KVA modules. There are two cable connection way for bypass input, the first one separate mains input and bypass input(from the default), if bypass source are not available, you can short mains and bypass input through appendix accessory copper, following power distribution cabinet chart shows the details.

### ◆ 80KVA module cable connection

Inlet and outlet channels are shown in figure 2.10, cable connected ups through inlet and outlet channels.

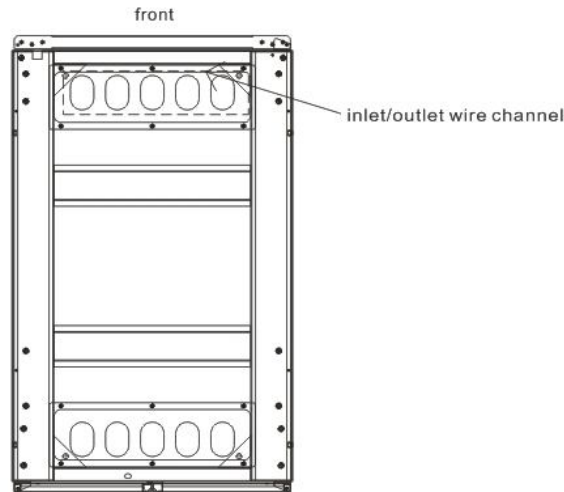

Figure 2.10 Inlet and Outlet Wiring Channel of 80KVA

Cable connection steps are:

- 1) Open the UPS input and output switch panels to expose the copper rows.

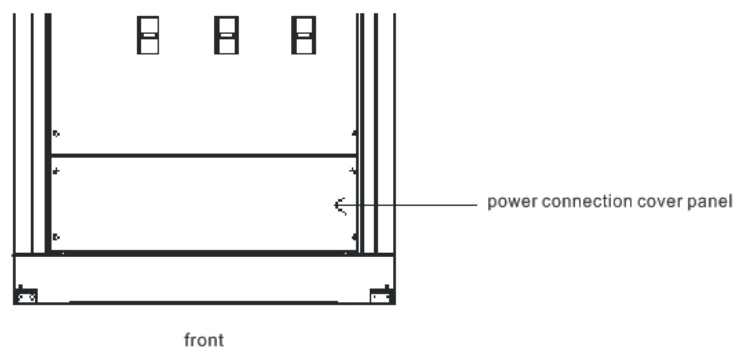

Figure 2.11 Power connection cover panel of 80KVA System



2) Connect the mains input line, battery input line, and load output line with UPS connection terminals through input and output line channels of cabinet according to phase order shown in figure 2.12.

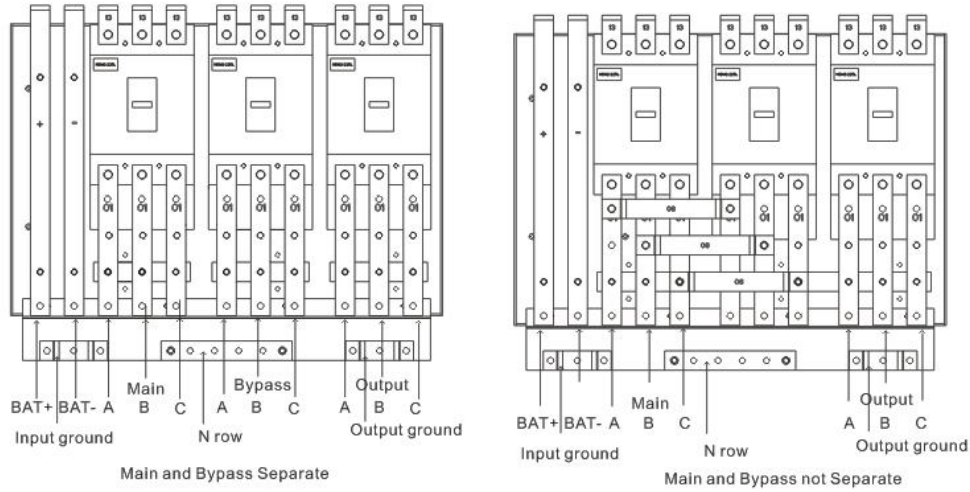

Figure 2.12 Input and Output Wiring Boards of 80KVA System

3) Install the power distribution panels back into the cabinet.

◆ 160KVA module cable connection

Inlet and outlet channels are shown in figure 2.13:

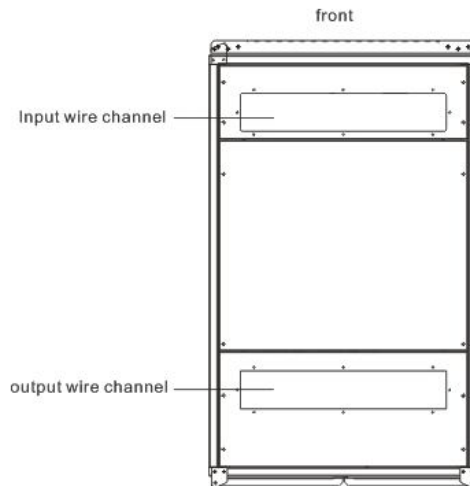

Figure 2.13 Inlet and Outlet Wiring Channel of 160KVA System (Top view)

Mains input and battery string connect ups through inlet channel, ups and loads connected by output string through outlet channel.

Cable connected as follows: :

1. Open the UPS input and output switch panels to expose the copper rows.

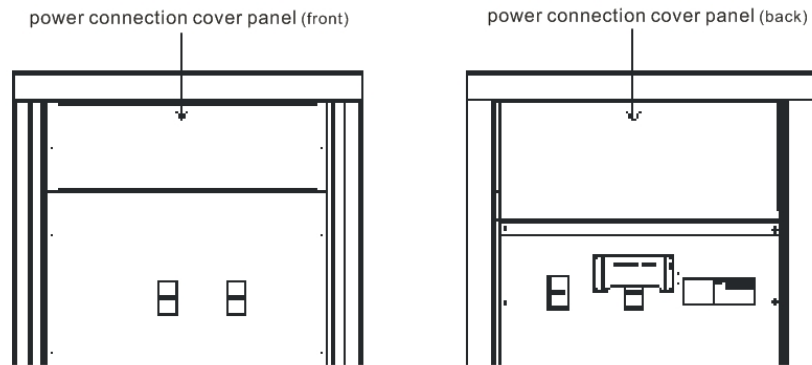

Figure 2.14 Power connection cover panel of 160KVA System

2. Connect the mains input line, bypass input line, and battery input line with UPS connection terminals through input and output line channels of cabinet according to phase order shown in figure 2.15.



图 2.15 Input Wiring Boards of 160KVA System

Output lines connect the output terminal in the back of ups shown in figure 2.16.

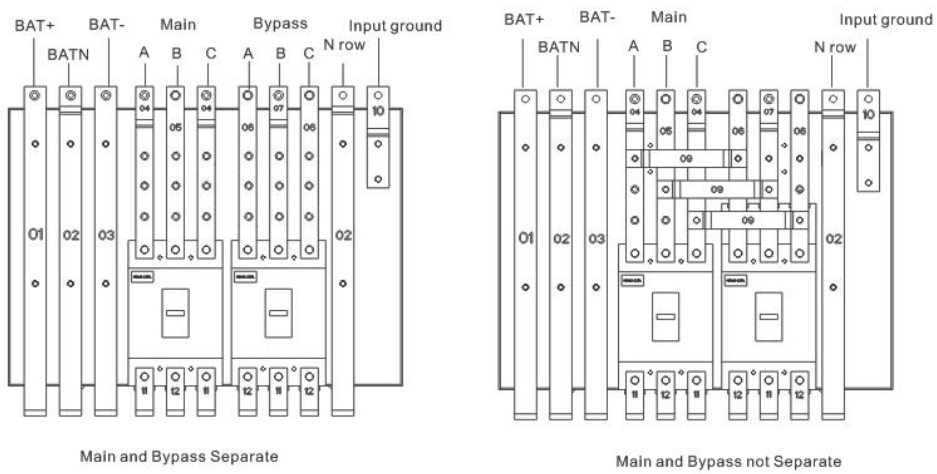
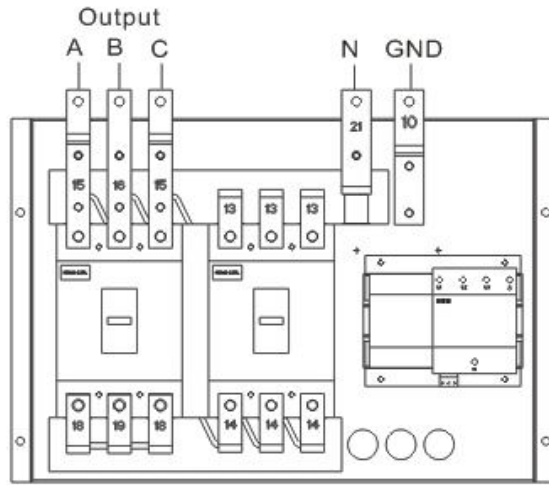

Figure 2.16 Output Wiring Boards of 160KVA System

3. Install the input and output power distribution boards back into the cabinet.

◆ 200KVA module cable connection

Figure 2.17 shows the input and output cable channel, battery and mains input get in through the front channel, bypass and output line get in through the back channel.



图 2.17 Inlet and Outlet Wiring Channel of 200KVA System(Top view)

Cable connected as follows:

- 1) Open the power distribution board to expose the power distribution panel.

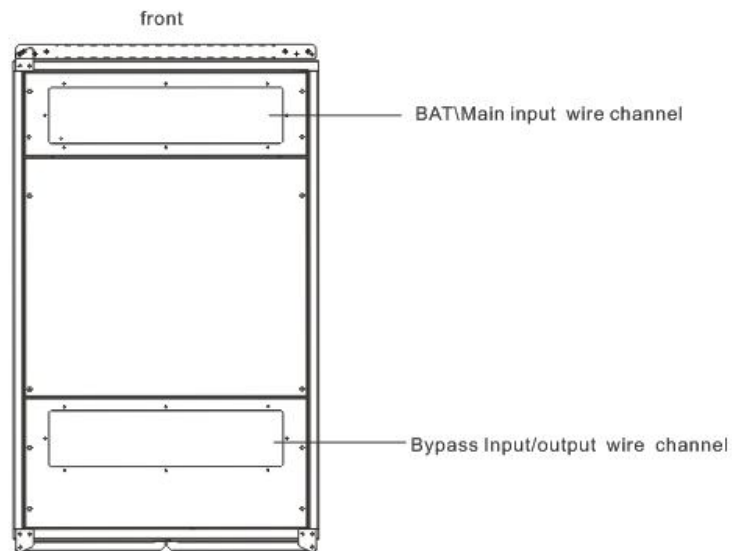

图 2.18 Power connection cover panel of 200KVA System

- 2) Connect the battery cable, input cable and output cable with copper bars through the inlet and outlet channels on the top of cabinet. The cable phase showed in Figure 2.19.

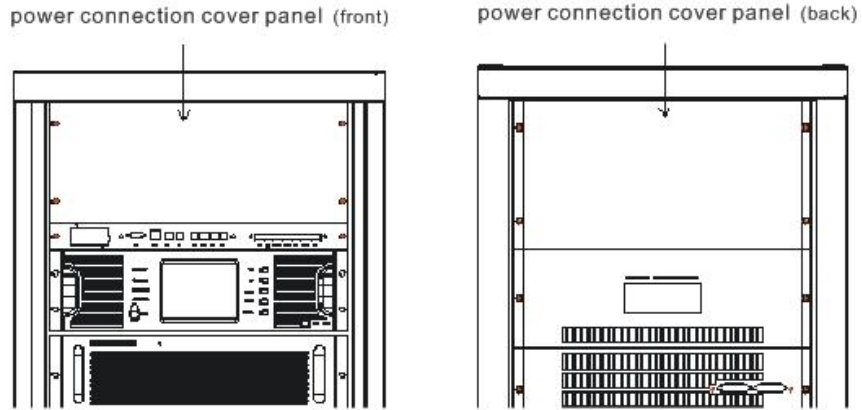

图 2.19 Power distribution board of 200KVA module cabinet

- 3) Install board back after wiring.

◆ 400KVA module cable connection

- 1) 400KVA module is consist of two 200KVA modules which share the power distribution system, It means that the UPS system mains input, bypass input, output and battery parallel connected separately, and separate connect with mains input, bypass input, output and battery of the two cabinet(like one 200KVA module cable connection).
- 2) One up to 5 meters long double insulation shielded wire is offered, As figure 1.6 showed in chapter one. The male signal cable access to female communication interface of cabinet 1, the female signal cable outlet from the right side of cabinet 1 and inlet from the left side of cabinet 2 to connect with the male communication interface. Please keep the signal cable is handing up in the air, in case of biting by mouse or dipping in water.
- 3) Please check whether the connection is correct or not after connection complete, otherwise no UPS start-up are permit.
- 4) Install the input and output power distribution board back into the cabinet.

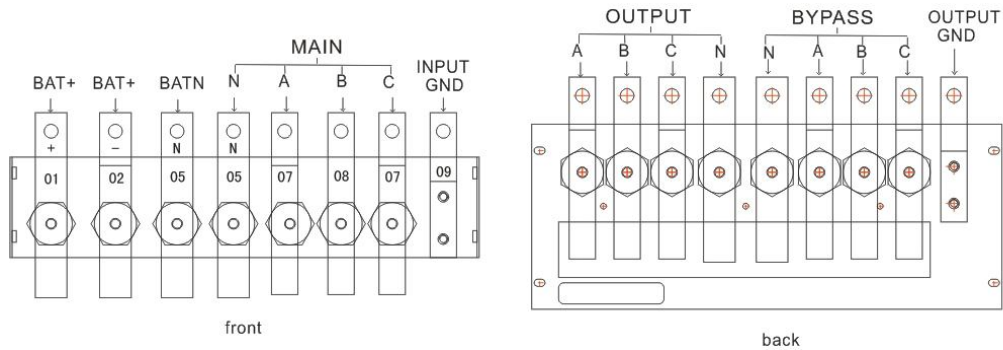
## 2.5 Battery Connection

Battery group for this machine is positive and negative battery group framework, total number of battery can be selected from 32 to 40 (even numbers), and quantities of positive and negative batteries shall be the same.

Battery connection chart is shown in figure 2.20:

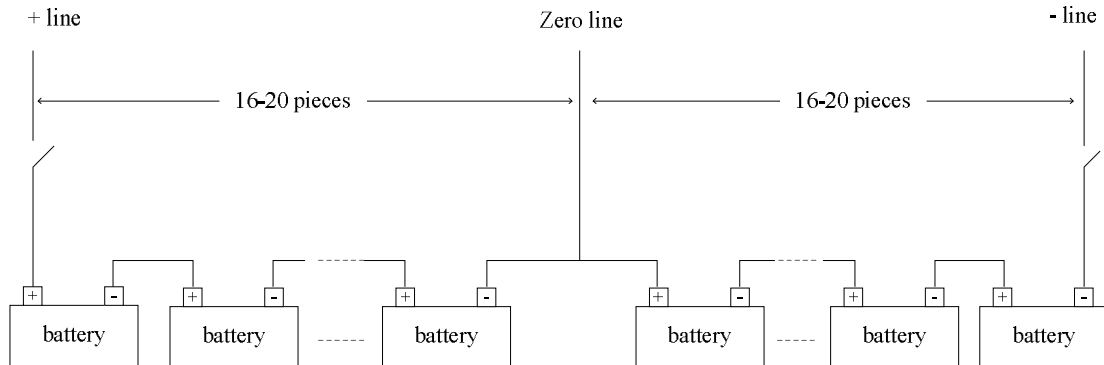

Figure 2.20 Battery Connection Chart

As shown in figure 2.20, connect all batteries in series, and lead a zero line from middle connection point of battery groups, so it shall be three lines together with positive and negative ends of battery group to connect with battery connecting terminals of UPS. Batteries between positive end of battery group and zero line are called positive batteries, and batteries between negative end of battery group and zero line are called negative batteries. User can select the capability and number of battery according to its demand. It must add a DC breaker between battery group and UPS to play a role of current-limiting protection also can open and close the battery group when maintaining.

The following safety notes shall be noted all the time when mounting batteries:

1. Electric shock may occur when installing the batteries, high short-circuit current may cause fire;
2. Voltage of battery groups can be 480Vdc which may cause death, so please obey safety attentions for voltage operation;
3. Only qualified personal can install and maintain the batteries;
4. Wear protective eyewear to prevent accident caused by electric arc;
5. Take off ring, watch, necklace, bracelet, and other aglets;
6. Use tools with insulated hands;
7. It shall break down the breaker of battery when connecting lines between UPS and battery. It must ensure that the sequence and polarity of connection are correct after finished connection;
8. Please contact customer service department of our company if the user needs to change the number of used batteries during normal application. Please do not operate it solely.

## 2.6 Installation of Modules

### 2.6.1 Steps of module installation

1. Take off decoration panel in front face of vacant slot of module needing to be installed on the cabinet.
2. Insert the charger module and power module into corresponding module slot from upper to lower (installing according to corresponding locations shown in figure 1.2).
3. There is a screw positing hole in both sides of module, fix the module with screws dismantled from panel on cabinet.
4. Screw fixing the module must be specific CHDS (M5\*16), otherwise it may damage inner switch of cabinet or cause the machine cannot be turned on.

**Note:** it shall push slowly so that the module can be inserted into the cabinet completely when inserting the module into UPS. It shall pay attention to that connecting terminal between them shall be inserted tightly without overexert, otherwise it may damage the contact pin of terminal.

### 2.6.2 Hot-swapping of module

660 modularized UPS supports hot-swap of module which can take online hot-swap for all modules. UPS can monitor connection conditions of all modules at any time and turn on or off the modules according to connection condition of them

#### 1. Insertion of module

- 1) Mount the UPS module into corresponding blank plot of cabinet, and then push the module into the cabinet until it is inserted into the cabinet completely.
- 2) Use specific CHDS to lock the screw location holes in two sides of module panel tightly (screw in left side must be fastened within 30s after the module is inserted).
- 3) The UPS will start automatically if new module is detected, the starting is finished after a period time, and then the module is turned on.
- 4) When adding new module for battery module, it shall press the button of “ENTER” on control panel for 2s after the module is pushed into cabinet and screw is fastened, and then the module can build working power and turn on automatically.

#### 2. Extraction of module

Take off the screw of UPS module panel to stop running of the module, and then extract it after fan of the module stops rotating.

**Note:**

1. Positioning screw hole in left side of module controls the running of module, so proprietary screw shall be used. It shall fasten this screw within 30s after the module is pushed into cabinet.
2. The power module shall be pushed into cabinet after 30s since it is extracted, otherwise it may cause fault for the system.
3. All modules shall be mounted according to corresponding locations shown in figure 1.2, otherwise it may cause the machine cannot be turned on.

## Chapter 3: 660 Modularized UPS Operations

This chapter describes all enquiries and setting operations of UPS taken by operator, including starting of UPS, power off of UPS, all enquiry operations, and parameter setting, etc.

**Tips: instruction manual must be read carefully before implementing the following operations to avoid personal injury or equipment damage caused by misoperation.**

### 3.1 Introduction of Monitoring Module

As shown in figure 3.1, monitoring module mainly contains: LED indicator light, 5.7 inch multifunctional LCD touch wide screen and operation button.

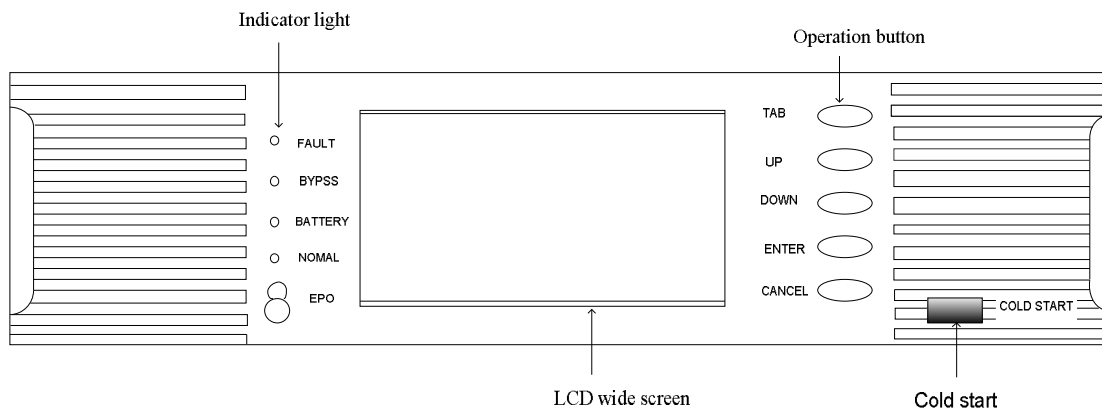

















Figure 3.1 Monitoring Module

Definitions of icons on panel silk-screen and LCD screen are listed in table 3.1:

Table 3.1 Silk-screen/Icon Illustration

Monitoring module panel	Icon/Silk-screen	Meaning
LED indicator light	FAULT	Warn
	BYPASS	Power supplied by bypass
	BATTERY	Power supplier by battery
	NOMAL	Power supplied by mains
		Set
		Charge module
		Battery

Icons on LCD touch screen		Power on
		Power off
		Input parameter
		Output parameter
		Return to main interface
		Return to previous menu
		Page down
		Page up
		History
		Module data
		Self-test and mute off
		Record enquiry
Operation buttons	TAB	Switch of touch/button-control
	UP	Cursor up
	DOWN	Cursor down
	ENTER	Confirm
	CANCEL	Return to touch-control from button-control
	COLD START	Cold start
	EPO	Emergency power off

LCD screen supports two kinds of control modes, button control and touch control.

#### 1. Button control

Press button of “TAB” under any interface to switch to button control mode, the selected icon is displayed in reverse, move the cursor by pressing button of “UP” or “DOWN”, press “ENTER” to select the icon where cursor locates at, and press “CANCEL” to return to touch screen control mode.

#### 2. Touch control

Take operations by clicking corresponding icons in LCD screen.



## 3.2 Startup operation

It shall check whether all screws are fastened and all connections are correct or not before starting the machine. Input, output, and battery breakers shall be in off state.

### 3.2.1 Startup to AC mode

1. Startup at AC mode directly

1) Connect the main power

Close input breaker to connect the main power. The UPS screen starts to work then and “WELCOME TO USE ONLINE UPS” interface occurs.



The image shows a simple logo interface with the text "WELCOME TO USE ONLINE UPS" centered in a large, bold, sans-serif font. The text is enclosed in a thin rectangular border.

Figure 3.2 Logo interface

It will be refreshed to main interface after 1s.

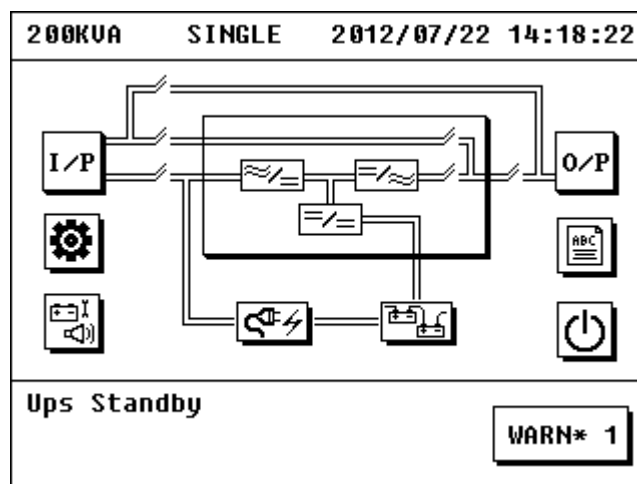

Figure 3.3 Main Interface

## 2) Startup UPS

Click icon of power on in main interface to pop the interface of power on. Click icon of “TO\_INV” and then UPS starts to power on at AC mode.

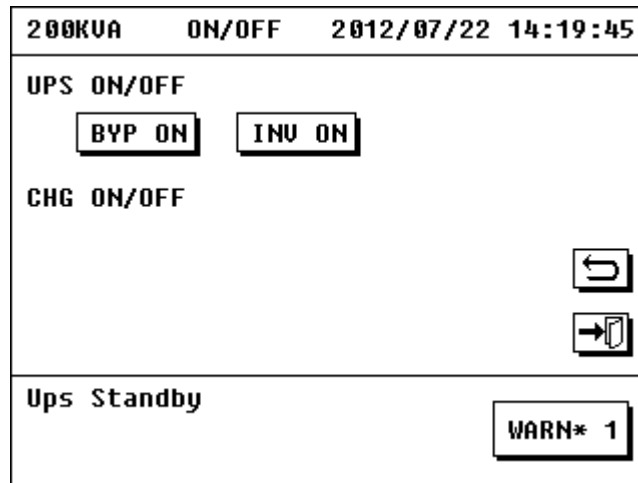

Figure 3.4 Power on interface

Process of starting up UPS at mains mode will be finished after a short time, and then the indicator LED in front panel of power module will on.

The charger module starts to power on automatically after the power module is started, the indicator LED in front panel of charger module is on after a time, and the starting up of charger module is finished.

## 3) Close battery and output breakers

Check whether the charging voltage is normal or not after starting up of UPS at AC mode is finished and charger module is started, close the battery and output breakers if it is normal, and then the UPS will be in normal operation.

Energy flow after started up at AC mode is shown in figure 3.5:

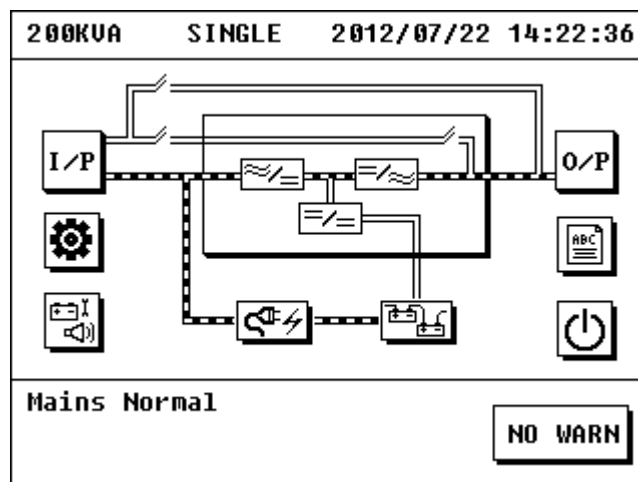
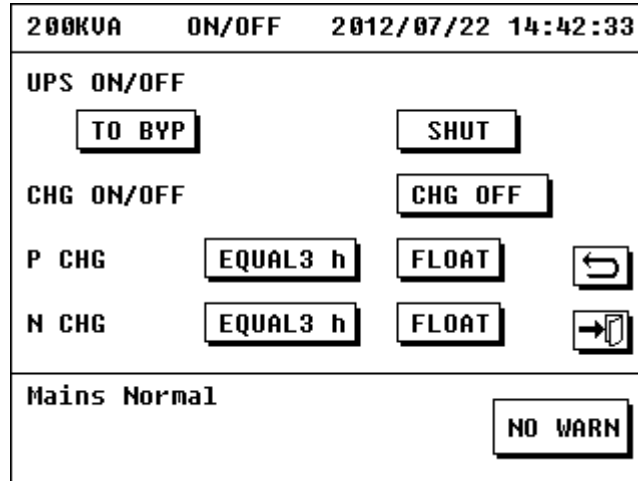

Figure 3.5 Operations under Normal Power

## 2. Switch Bypass mode to AC mode

If the module is working under bypass mode, click the power on icon in main interface to pop the power on interface



3.6 Power on interface

Click icon of “TO\_INV”, the UPS will begin to start to the AC mode. And starting up at AC mode will be finished after a time.

### 3.2.2 Startup at battery mode

If main input is fault, UPS can transfer to battery mode directly.

1. Close battery and input breakers, and connect the batteries.
2. Press button of “COLD STAR” in monitoring module panel to turn on the LCD screen. LCD screen displays main interface.

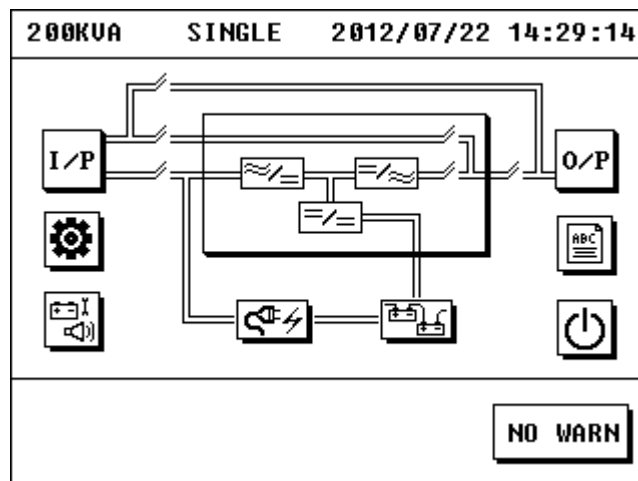

Figure 3.7 Main Interface

3. Press “ENTER” for 2s to build working power for power module and charger module, and then the fans of module starts to rotate.
4. Click power on icon in main interface to pop the power on interface. Click icon of “TO\_INV”, and

the starting under battery mode will be finished after a short time.

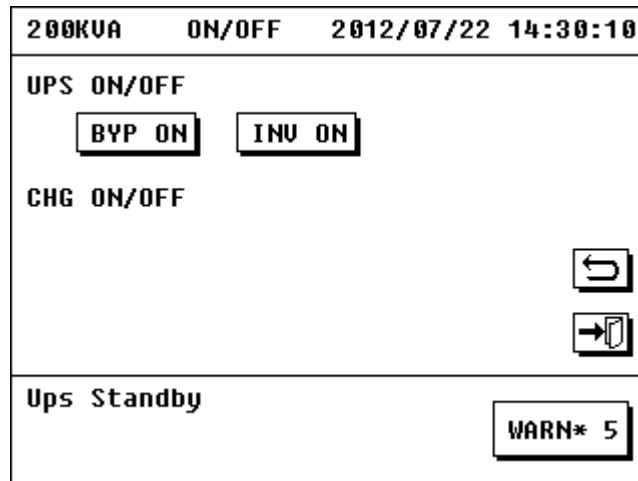

Figure 3.8 Power on interface

5. Close output breaker, and then the UPS output is normal and starting by battery is finished. Its energy flow is shown in figure 3.9:

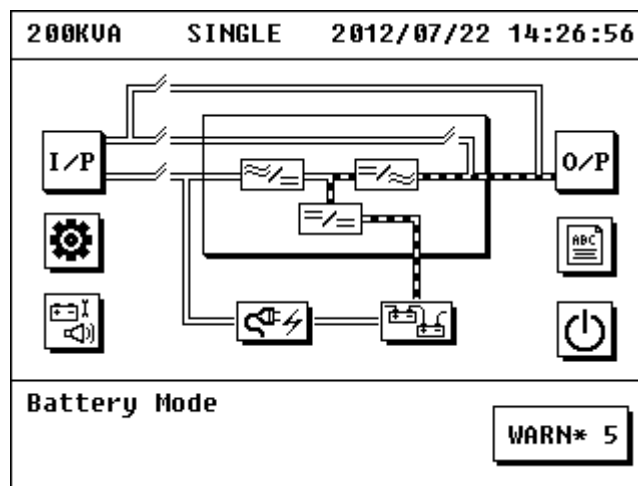

Figure 3.9 Battery Mode

### 3.2.3 Startup to bypass mode

It can switch to bypass mode directly at AC mode or in the case that machine is not started while main power is available (it is not allowed to switch to bypass mode directly in the case that the main power is available, but UPS has not been turned on with a isolating transformer connected to output).

1. Switch to bypass mode when UPS is starting (The main power is available, but UPS has not been turned on)

The UPS has not been started currently, and display of its main interface is shown in figure 3.10:

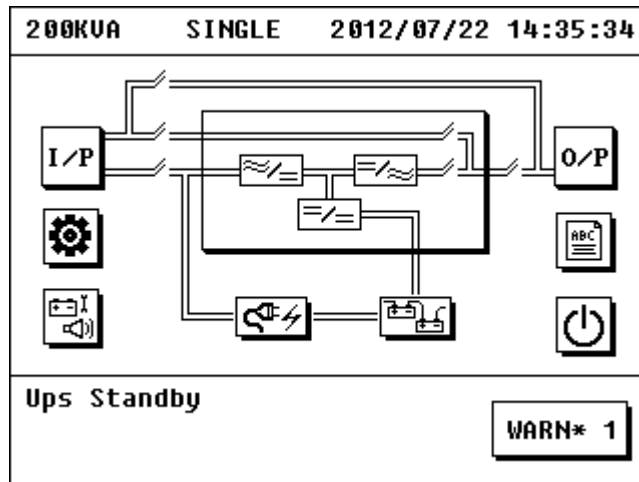

Figure 3.10 Main Interface

1) Click power on icon in main interface to pop the power on interface.

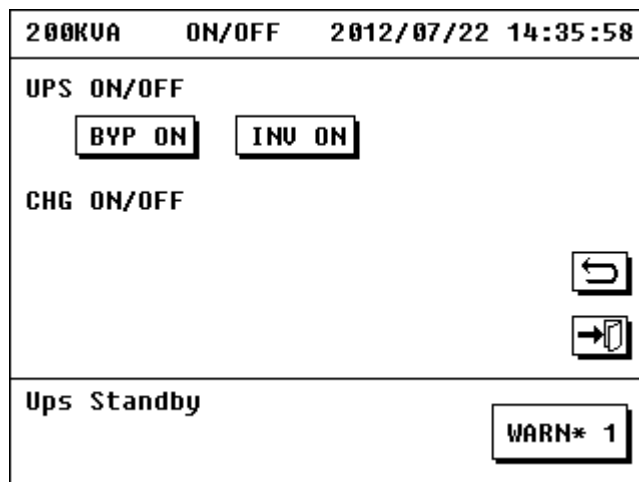

Figure 3.11 Power on interface

2) Click icon of “TO\_BYBP” to enter the bypass mode, and the bypass mode is started. The charger module will start automatically after a time.

3) Check the charging voltage of charger module, close battery and output breakers if the charging voltage is normal, and the bypass starts normal output.

Its energy flow chart is shown in figure 3.12:

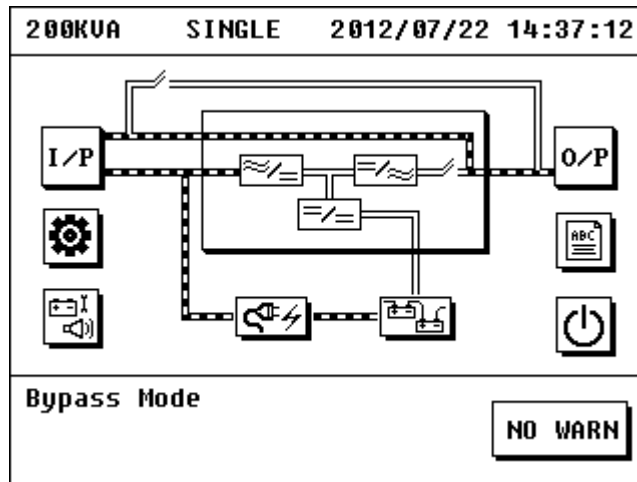

Figure 3.12 Bypass Mode

## 2. Switch to bypass from mains mode

The UPS is working under mains mode currently, click icon of power off in main interface to pop the power off interface.

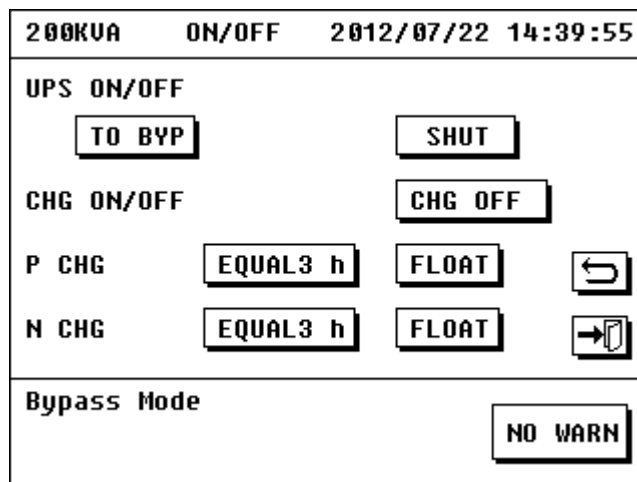

Figure 3.13 Power off interface

Click icon of “TO\_INV”, and then the system will enter into bypass mode.

### 3.2.4 Starting by manual self-test

In order to ensure the battery state of UPS and prolong working life of battery, battery need to be discharged and charged periodically to ensure to supply power for UPS normally when mains fails suddenly.

Click icon of self-test and mute off in main screen, the popped interfaces include “TEST\_10S”, “TEST\_10M”, “TEST\_LOW”, “CLR TEST”, and “MUTE ”. Click one of the first three options to select the test time. Select different test times according to the time of actual test period.

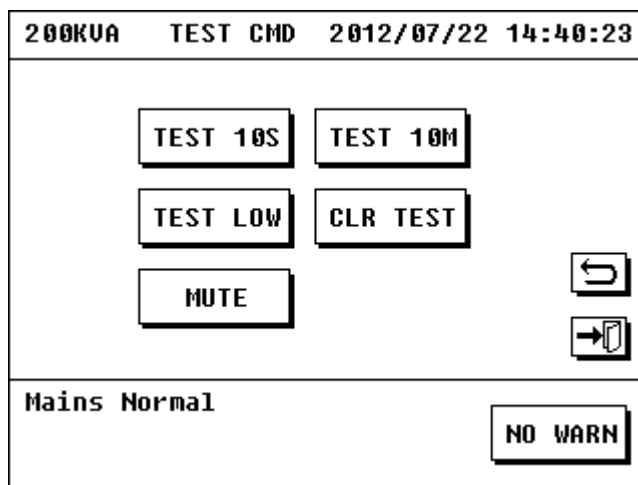

Figure 3.14 Self-test and Mute off Interface

### 3.2.5 Start of charger module

**Note: it needs to set the parameters of charger module and ensure that the pieces of battery and group can match with the connected battery groups before starting. (It shall be set by professional personal of the company)**

1. Charger module will start automatically to charge the battery when UPS is started under mains mode or bypass mode.
2. If the charger module is off and needs to be restarted, when the UPS is in mains mode or bypass mode it can click the power on icon in main interface to pop the power on interface, click icon of “CHG\_ON” below the “CHARGER POWER ON?”, and then the charger will be started. Starting of charger module is finished when the indicator light in charger module panel is on.

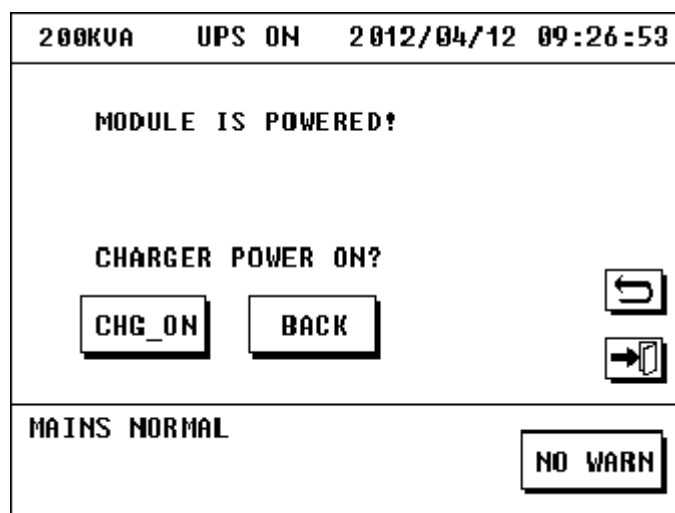

Figure 3.15 Power on Interface of Charger Module

### 3.3 Operation for Turning Off

#### 3.3.1 Power off under line module

The UPS is working under mains mode currently.

Click icon of power off in main interface to pop the power off interface. Click icon of “OFFUPS” to power off the UPS, and the charger module will off automatically at the same time.

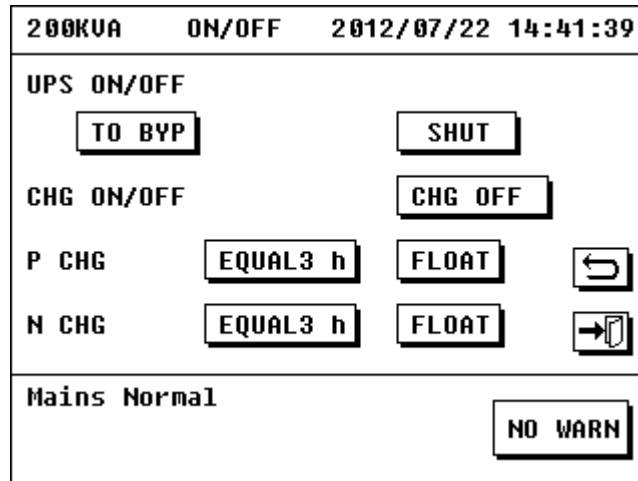

Figure 3.16 Interface of Power Off

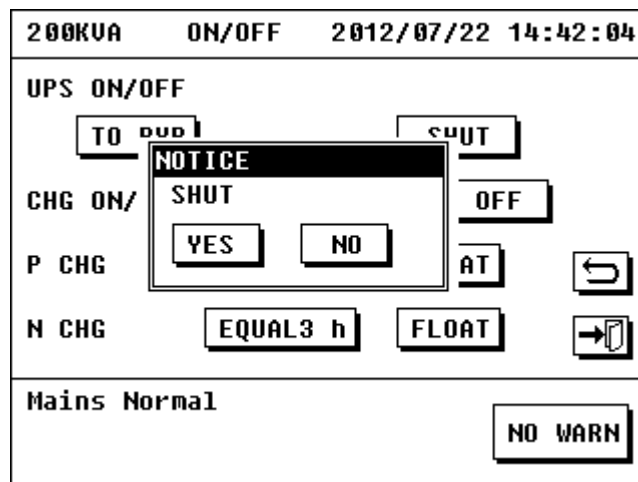

Figure 3.17 Power Off confirm Interface

#### 3.3.2 Power off under battery mode

The UPS is working under battery mode currently.

Click icon of power off in main interface to pop the power off interface. Click icon of “OFFUPS” to power off the UPS.



### 3.3.3 Power off under bypass mode

The UPS is working under bypass mode currently.

Click icon of power off in main interface to pop the power off interface. Click icon of “OFFBYP” to power off the UPS, and the charger module will be off at the same time.

### 3.3.4 Power off the charger module

1. The charger module will be off automatically if the machine is powered off under mains mode or bypass mode.
2. Power off the charger module when the machine is working under mains mode or bypass mode:
  - 1) Click icon of power off in main interface to pop the power off interface.

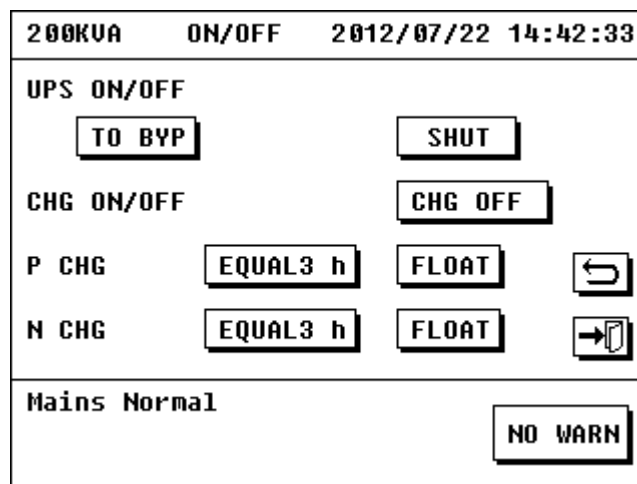

Figure 3.18 Power Off Interface

- 2) Click icon of “OFF” below “POWER OFF CHARGER?” to power off the charger module.

### 3.4 Operation for Emergency Power Off

Emergency power off (EPO) switch is used to power off the UPS under emergency situation (such as fire, flood, etc.). Press button of EPO in monitoring module, the UPS will cut off output at once and cut off the power in several seconds.

If it needs to power on the machine again, it shall take the power on operation after cutting off the normal input for 30s.

## 3.5 Operation for Maintenance Bypass

### 3.5.1 Starting of maintenance bypass

1. Select option of power off in LCD main interface, select icon of “TO\_BY P” in power off interface, and confirm the UPS is working under bypass mode in LCD screen.

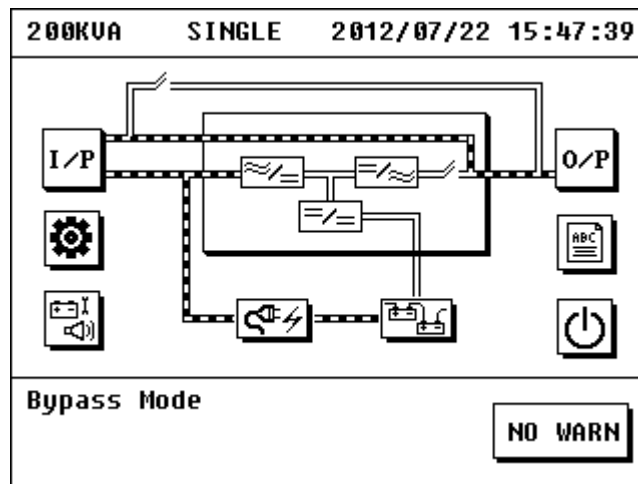

Figure 3.19 Bypass Mode

2. Open the cover of breaker of maintenance bypass, close the breaker of maintenance bypass, cut off the output and battery breakers, and then the UPS enters into maintenance bypass mode. Its energy flow is shown in figure 3.20:

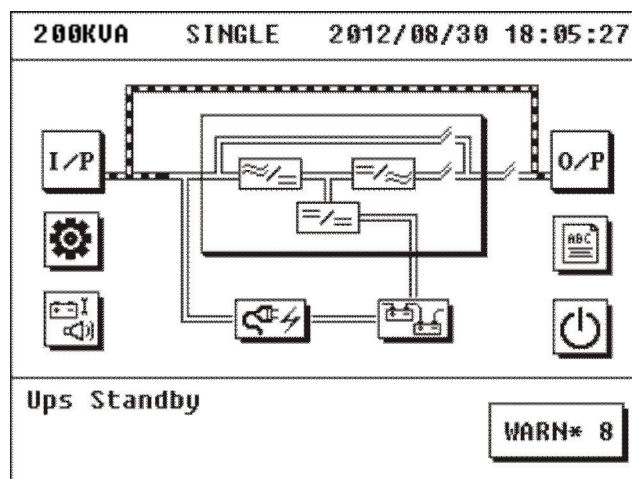

Figure 3.20 Maintenance Bypass Mode

Cut off the input breaker and you can take the maintenance operations.

### 3.5.2 Exit of maintenance bypass mode

1. Close the input breaker, the power modules builds working power and switches to bypass mode automatically, charger module starts automatically, and indicator light in front panel of module is on.

2. Close the output and battery breakers, cut off maintenance bypass breaker, put the baffle of maintenance bypass breaker, and then the warning “maintenance cover is open” in LCD screen disappears.
3. Select option of power on in LCD main interface, select “TO\_INV” in power on interface, the power module will start the inverter after 20s, and then UPS will be working under line mode.

### 3.6 Enquiry Operation

Enquiry operation is a parameter to inquiry the working condition and setting of UPS.

#### 3.6.1 Enquiry of input information

Click “IP” in main interface to pop the input parameter interface. The input parameter interface will display information including input voltage, input frequency, bypass voltage, and bypass frequency, etc.

200KVA		INPUT			2012/07/22 14:44:50	
	AN	BN	CN			
In Volt.(V)	233	235	235			
In Freq.(Hz)	49.9	49.9	49.9			
Byp Volt.(V)	234	235	234			
Byp Freq.(Hz)	49.9	49.9	49.9			
				↶		
				➡		
<b>Mains Normal</b>				<b>NO WARN</b>		

Figure 3.21 Input Parameter Interface

#### 3.6.2 Enquiry of output information

Click “OP” in main interface to pop the output parameter interface, and then information including output voltage, output current, output frequency, active power, apparent power, and load factor, etc. will be shown.

200KVA		OUTPUT			2012/07/22 14:45:57	
	AN	BN	CN			
Out Volt.(V)	222.7	222.7	222.6			
Out Curr.(A)	0	0	0			
Out Freq.(Hz)	49.9	49.9	49.9			
Pout(kW)	0	0	0			
Sout(kVA)	0	0	0			
Load(%)	0	0	0			
				↶		
				➡		
<b>Mains Normal</b>				<b>NO WARN</b>		

Figure 3.22 Output Parameter Display

### 3.6.3 Enquiry of information of power module

Click module data icon in main interface to pop the module information interface.

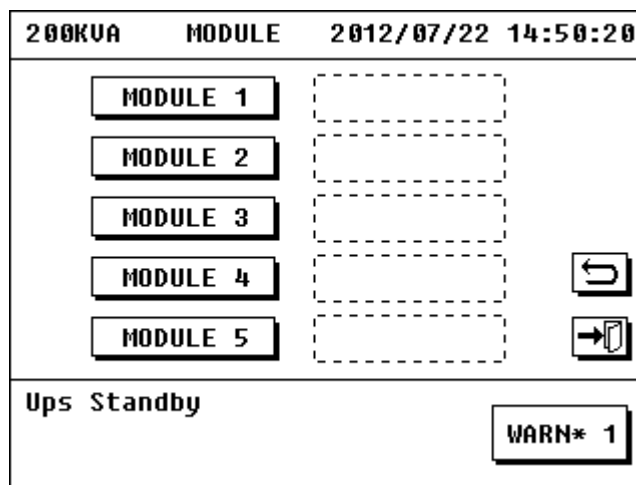

Figure 3.23 Chart of Module Information Interface

LCD screen will display the module at corresponding position if the power module is inserted into plot of cabinet; it means no power module is inserted into the plot if nothing is displayed in LCD screen.

If the panel screw is not locked or not fastened after mounting of module, the module will pop the warning of “EPO ACTIVE”, and it cannot take operations of power on then.

Click icons of “MODULE 1” to “MODULE 8” in “MODULE INF” interface to inquiry data information of every module. The information includes: three-phase input voltage, bypass voltage, output voltage, output current, input frequency, output frequency, and module temperature. It can switch data information of every module by button of page up or page down.

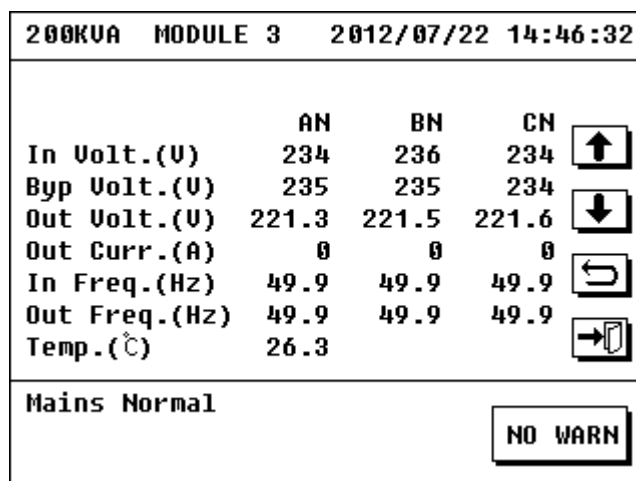

Figure 3.24 Data Interface of Single Module

### 3.6.4 Enquiry of information of charger module

Click icon of charger module in main interface to pop option interface of charger module.

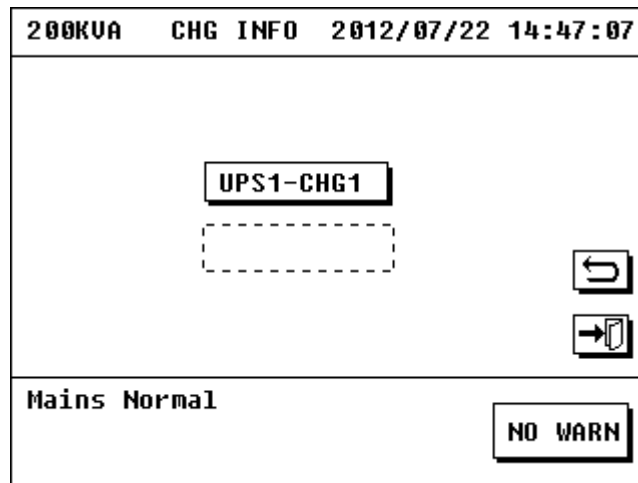

Figure 3.25 Option Interface of Charger

Click “CHARGER 1” to inquiry information of charger module.

Information of charger module includes: state of charger module and parameter of charger module (can be switched by button of page up or page down).

The interface of charger module state will display: charger state, charger temperature, positive/negative charger voltage, and positive/negative charger current.

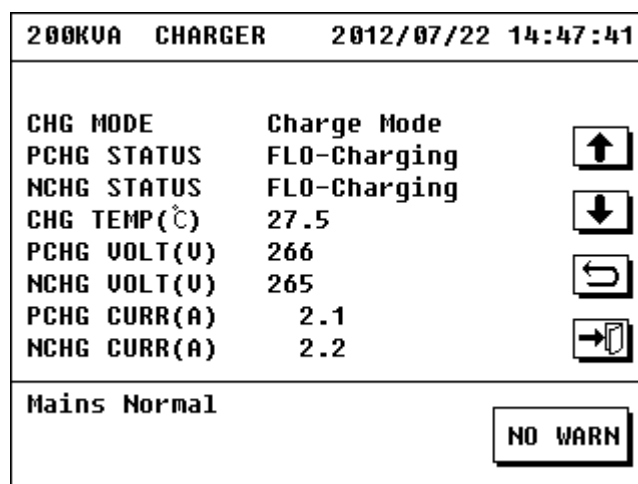

Figure 3.26 Interface of Charger State

It can switch to interface of charger parameter by pressing button of page up or down, and the following information will be displayed: float charge voltage, even charge voltage, temperature compensation setting, positive/negative charging speed, and maximum positive/negative charging current.





200KVA CHG INFO 2012/07/22 14:48:06		
FLO VOLT(V)	267.0	
EQU VOLT(V)	285.0	
TEMP COMP(mV/°C)	Closed	
P/N CHARGE RATE(C)	0.10	
MAX P/N CHG CURR(A)	10.0	
BAT VOLT LOW(V)	11.00	
BAT SHUTDOWN VOLT(V)	10.20	
Mains Normal		

Figure 3.27 Interface of Charger Parameter

### 3.6.5 Enquiry of battery information

Click icon of battery in main interface to enter into interface of battery parameter. It will display: number of battery, groups, connection state, battery voltage, battery remain time, battery remain capability, battery temperature, time of next self-test.

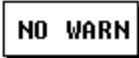

200KVA BAT INFO 2012/07/22 14:48:52		
BAT INFO	100AH*20pcs*1 groups	
BAT STATE	Battery Charging	
P/N VOLT(V)	268/268	
BAT A/B TEMP(°C)	Not Detected	
BAT C/D TEMP(°C)	Not Detected	
BAT REMAIN TIME(Min)	---	
BAT REMAIN CAP (%)	100	
NEXT TEST	2012/08/19 14:48:36	
Mains Normal		

Figure 3.28 Display of Interface of Battery parameters

### 3.6.6 Enquiry of current warn

Click icon of “WARN” in main interface to pop current warning information.

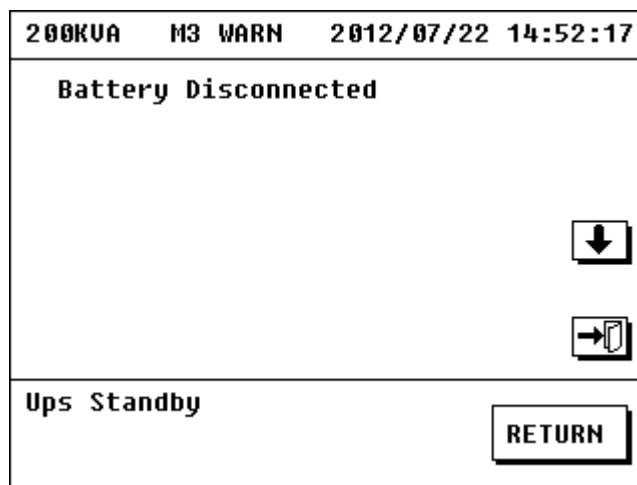

Figure 3.29 Warn Interface

### 3.6.7 Enquiry of history

Click icon of module data in main interface to pop the interface of module data, and then click icon of history to pop the interface of UPS history. It contains: “fault record”, “operate record”, “warn record”, and “status record”.

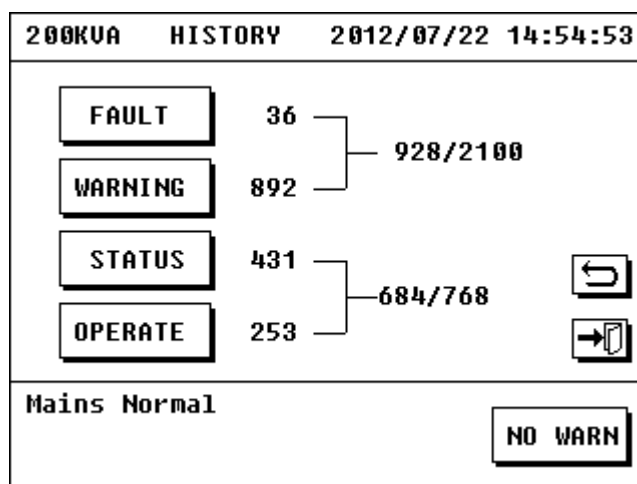

Figure 3.30 Interface of History

### 1. Fault record:

“Fault record” records all faults occurred during operation of UPS.





200KVA	FAULT	2012/07/22 14:55:32	
21	2012/07/19 16:53:28:368 M2-1 Bus Volt High		
22	2012/07/19 16:53:33:328 M2-1 Bus Volt Low		
23	2012/07/19 16:53:33:824 M1-1 Bus Volt Low		
24	2012/07/19 16:53:37:544 M2-1 Bus Imbalance		
Mains Normal			

Figure 3.31 Interface of Fault Record

### 2. Warn record

“Warn record” records reasons for all warns when warns occurred for UPS.



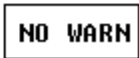

200KVA	WARNING	2012/07/22 14:56:05	
889	2012/07/22 14:52:02:264 C1-1 Battery Disconnected		
890	2012/07/22 14:52:54:096 M5-1 Module Unlocked		
891	2012/07/22 14:53:02:776 M4-1 Module Unlocked		
892	2012/07/22 14:53:12:448 M2-1 Module Unlocked		
Mains Normal			

Figure 3.32 Interface of Warn Record

Fault record and warn record can record 3150 pieces at most and the earliest records will be replaced by new record if number of all records exceeds 3150. All records are listed by inverted order of time.

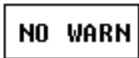

### 3. Operate records

“Operate record” records all operations of UPS taken by user.





200KVA	OPERATE	2012/07/22	14:56:51	
237	2012/07/22 14:44:25:367			
	Start Up Charger			
238	2012/07/22 14:48:36:155			
	Self Test Set			
239	2012/07/22 14:49:20:041			
	Shut Down UPS			
240	2012/07/22 14:49:28:008			
	Module 4 IN			
Mains Normal				

Figure 3.33 Display Chart of Interface of Operate Record

### 4. Status Record

Status record records all working mode of UPS under different periods.



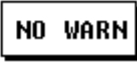

200KVA	STATUS	2012/07/22	14:57:19	
425	2012/07/22 14:51:37:487			
	CHG Power On Mode			
426	2012/07/22 14:51:38:487			
	MDL Standby Mode			
427	2012/07/22 14:51:38:487			
	CHG Standby Mode			
428	2012/07/22 14:54:08:487			
	MDL Line Mode			
Mains Normal				

Figure 3.34 Display Chart of Interface of Status Record

Operate record and status record can save 768 pieces at most and the earliest records will be replaced by new record if number of all records exceeds 768. All records are listed by inverted order of time.

### 5. Enquiry record

Click icon of enquiry record in all record interfaces to pop the interfaces of record enquiry. Enter the record time, it can inquiry records before and after the entered time.

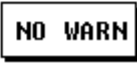
### 3.6.8 Enquiry of current setting

Click icon of setting in main interface to pop the setting interface.

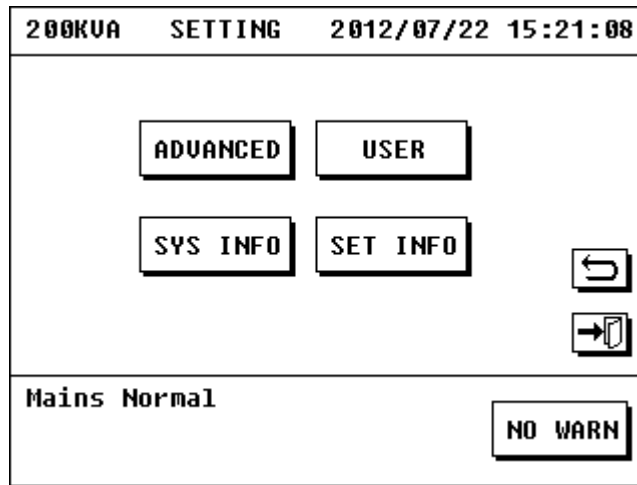

Figure 3.35 Setting Interface

Click icon of “current setting” to pop the current setting interface of UPS. Information contained in the interface includes: cabinet No., status of converter mode, status of charge mode, status of auto start, test mode, status of redundancy setting, and contact telephone.

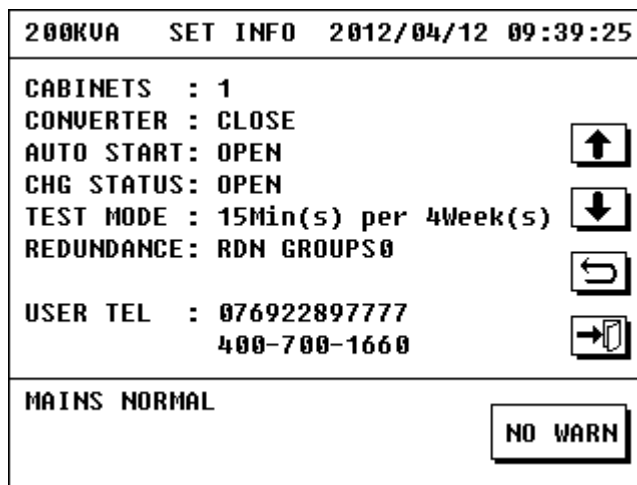

Figure 3.36 Display of Current Setting Interface

### 3.6.9 Enquiry of system information

Click icon of setting in main interface to pop the setting interface. Click icon of system setting to pop the system information of the machine, including: sequence No., module, software edition, producer, telephone, and website.

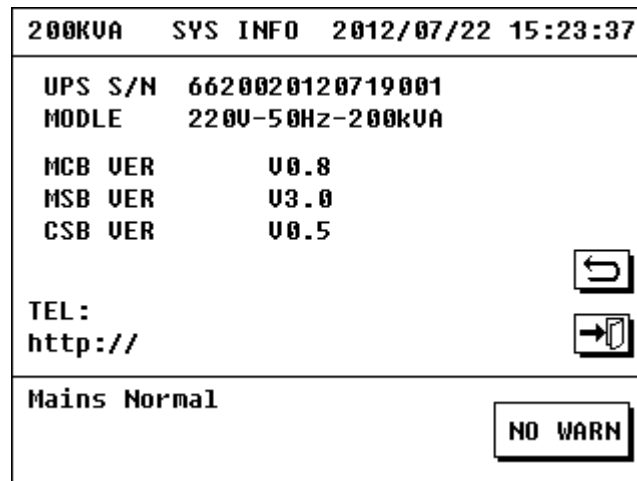

Figure 3.37 Interface of System Information

### 3.7 Operations for User Set

**Warn: operation for user set is used for setting UPS parameters, and nonprofessional personal shall not take any setting operations.**

Click icon of “USER SET” in setting interface to pop the password input interface of user set.

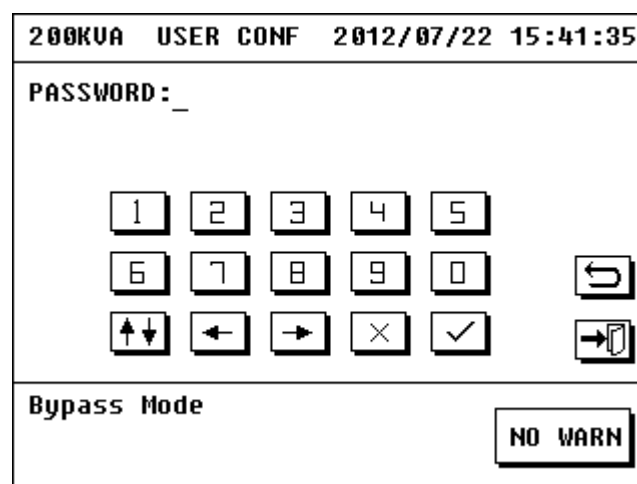

Figure 3.38 Password Input Interface

Enter correct password (initial password is 666666) to pop the user set interface, including: language set, time set, auto test set, redundancy set, protocol set, password set, touch set, and telephone set.

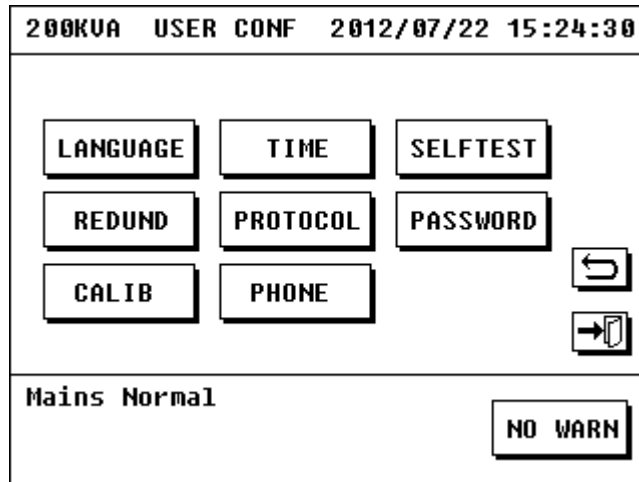

Figure 3.39 User Set Interface

### 3.7.1 Language set

LCD screen of 660 series can provide two languages, Chinese and English, for option. It can select language by “LANGUAGE SET”.

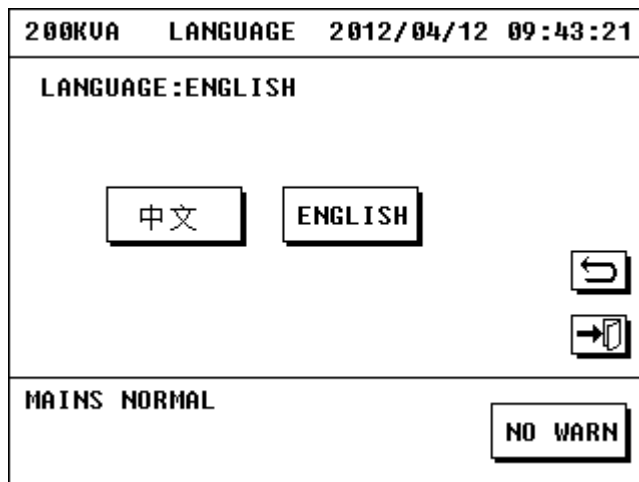

Figure 3.40 Language Set Interface

### 3.7.2 Time set

Click icon of “TIME SET” in user set interface to enter into time set interface. It can change the displayed time of UPS by entering current time.

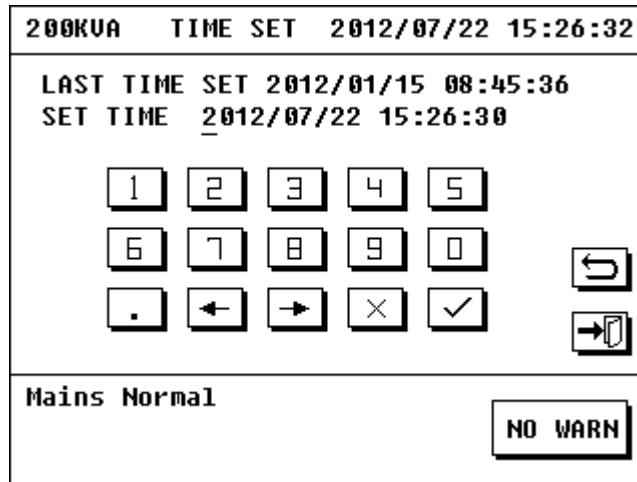

Figure 3.41 Time Set Interface

### 3.7.3 Auto self-test set

Click icon of self-test setting in user set interface to pop the self-test set interface.

Its display is shown in figure 3.42, auto self-test interface includes: on and off of self-test, run cycle of self-test, and duration of self-test for every time.

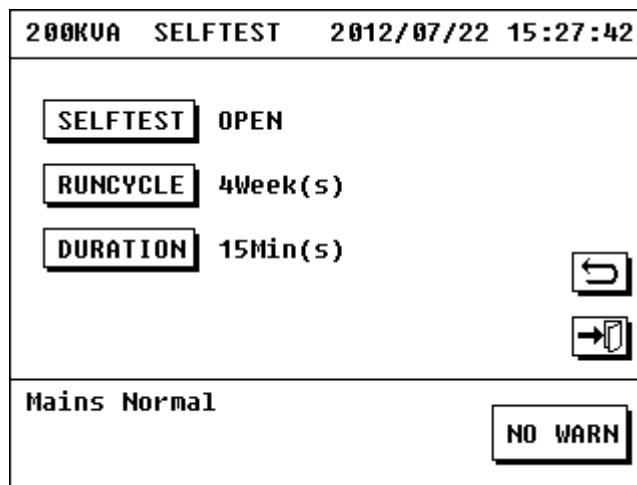

Figure 3.42 Self-test Set

It shall select proper self-test duration and time according to personal requirement.

### 3.7.4 Redundancy set

Click icon of “redundancy set” in user set interface to enter into redundancy set interface. Enter number of redundancy group to confirm redundancy of UPS.

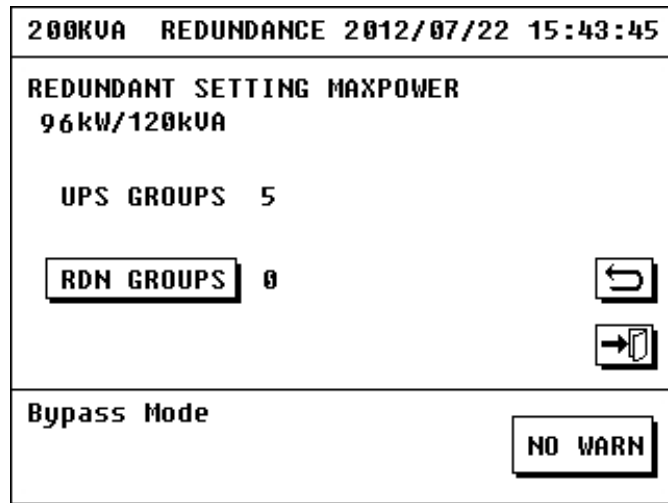

Figure 3.43 Redundancy Set Interface

### 3.7.5 Protocol Set

Click icon of “protocol set” in user set interface to pop the protocol set interface.

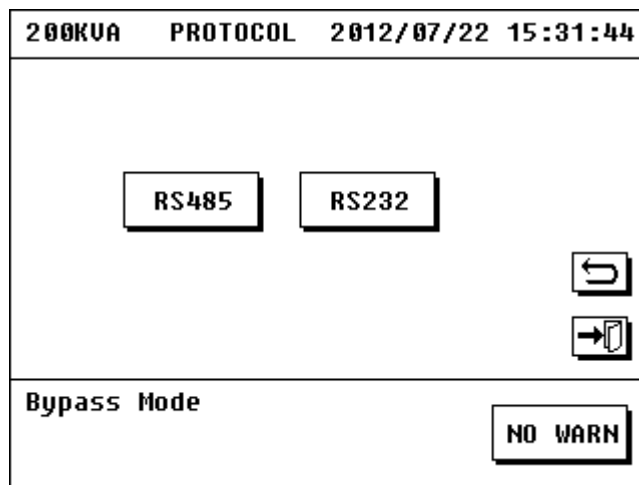

Figure 3.44 Protocol Set Interface

There are two optional communication ports, “RS232” and “RS485”.  
Click icon of “RS232”, and then communication port set interface will be popped.

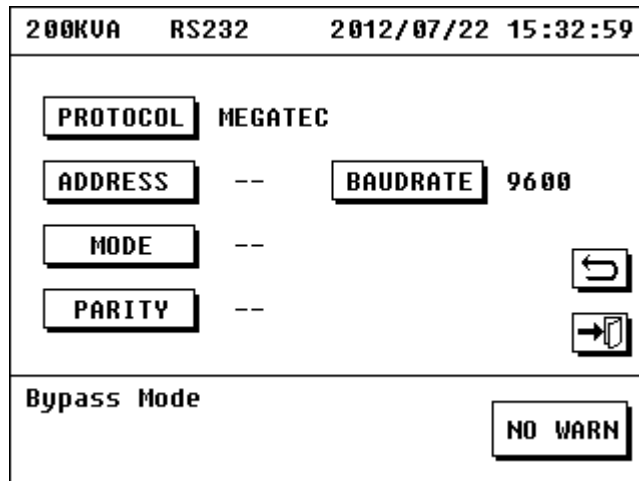

Figure 3.45 Communication Port Set Interface

Port property shall be set by demand.

### 3.7.6 Password set

Click icon of “password set” in user set interface to pop the password set interface.

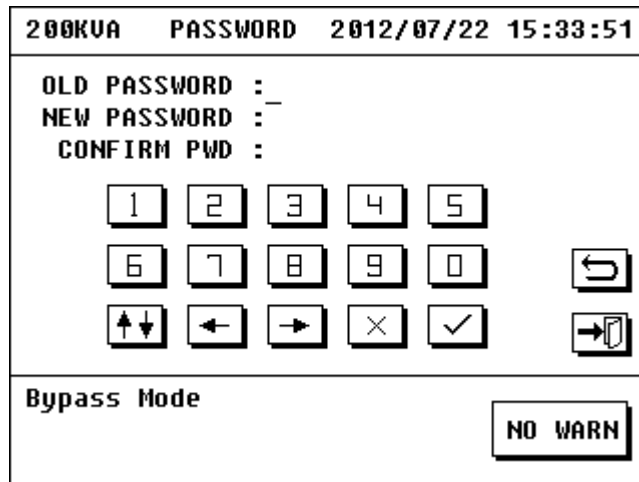

Figure 3.46 Password Set Interface

The password is required when entering user set interface.

Enter original password and new password to change the password (initial password is 666666).

### 3.7.7 Touch set

If the touch click is not so sensible, it can recover the sensitivity of touch screen through touch set.

Click icon of “touch screen set” in set interface to pop the calibrate interface of touch screen. Click specified site according to order, and then the sensitivity of touch screen will be recovered.

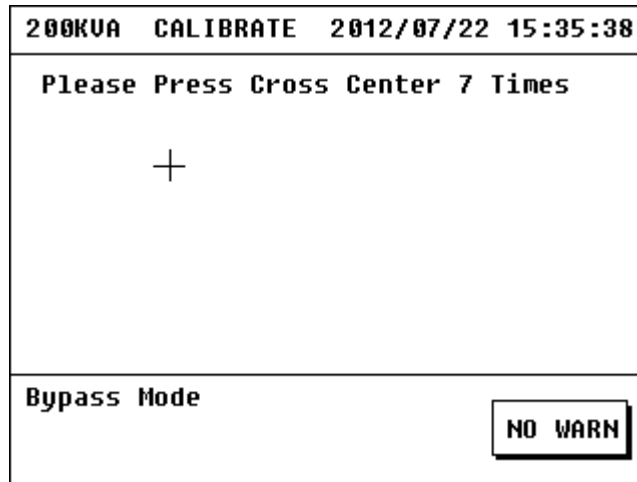

Figure 3.47 Calibrate Interface of Touch Screen

**Note: object used to click the touch screen shall not be too sharp when taking touch set, otherwise it will damage the screen.**

It can change the contact telephone of agency by telephone set.

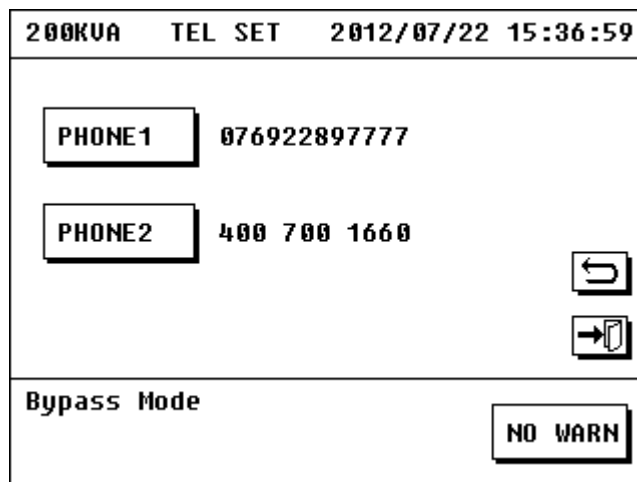

Figure 3.48 Telephone set interface



### 3.7.9 Mute off

Click icon of battery self-test and mute off in main interface to pop interface of battery self-test and mute off. Click “MUTE OFF” in self-test interface to mute the warning sound.

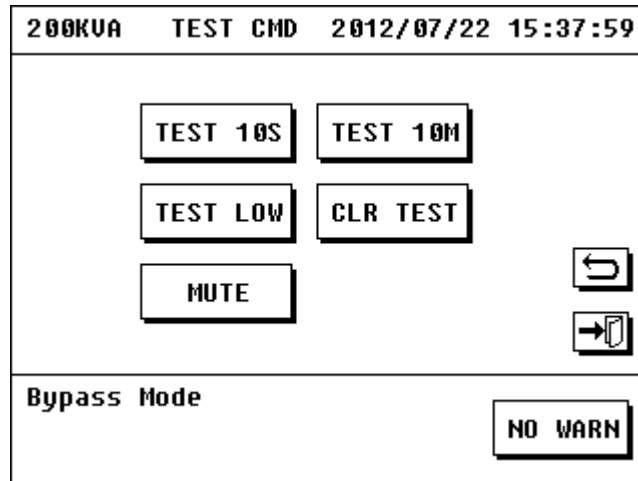

Figure 3.49 Interface of Self-test and Mute off

## Chapter 4: UPS Repairing and Maintenance

### 4.1 UPS Repairing and Maintenance

#### 4.1.1 Rated Power and features of load shall be considered when using UPS

Rated output power of UPS is the key parameter to express how much power load the product can drive, it changes along with alteration of load power factor, for example, 1 KVa UPS maybe cannot drive 1 KVa load. UPS shall not be under full load condition in order to prolong working life of UPS. Load capability of standby UPS shall be 60%~70% of rated power, and that of online UPS shall be 70%~80% of rated power. At the same time, the UPS shall not work under over under-loading condition for a long time.

#### 4.1.2 Ensure induction stroke protection of UPS

Lightening stroke is the natural enemy of all electrical equipments, so it must ensure the effective shielding and ground protection of UPS against lightening stroke. Lightening stroke may cause inductive high potential pulse due to electromagnetic induction. The high potential pulse may enter into the UPS along with power line or communication line, while there are so many microelectronic devices such as CMOS integrated circuit modules and CPU used for control in the UPS which are very sensitive to electromagnetic pulse of lightening, therefore, the devices are very easy to be damaged. Although our UPS has effective shielding and good protection ground measure, user still needs to adopt lightening protection and over-voltage protection for power line and communication line (such as remote monitoring signal line).

#### 4.1.3 Notes fr using, repairing and maintenance

- ✧ It must obey the product introduction when using UPS. Related stipulations in using manual can ensure all firing lines, zero lines, and earth lines meet requirements, so user shall not change its order without allowance.
- ✧ Any operation shall strictly comply with correct order of power on and off. It shall avoid excessive fluctuation of voltage output of UPS caused by sudden increasing or reducing of load so that the UPS cannot work in normal.
- ✧ It is strictly forbidden to power on and off the UPS frequently. It requires for 30s after the UPS is powered off and before starting it again, otherwise, fault may occurred for UPS.
- ✧ It is forbidden to operate under over-load. Maximum starting load of UPS shall be controlled within 80%, and the inverter may be damaged under inverter condition if it is operated under over-load condition. Experience proves that the best operation mode is to control the load within 30~60% of rated output power for most UPS powers.
- ✧ Discharging requirement of battery: in general, the UPS is equipped with protection measures for discharging of battery, but the battery will recover to certain voltage after it is discharged so that the protection is powered off, and it is not allowed to restart the machine, otherwise, it may cause over-discharging of battery. The battery shall be used normally after it is recharged.

- ✧ For new bought UPS (or for UPS stored for a long time), it only can be operated after the battery is charged. Otherwise, the standby time will not be ensured.
- ✧ For UPS without power off for a long time, its battery shall be discharged for every 3~6 months and then recharged again. It can prolong the working life of battery by this way.
- ✧ For UPS stored for a long time, it shall be started and charged for every 3~6 months, otherwise, it may damage the host and battery of UPS.
- ✧ The UPS shall be maintained periodically. Clean dust inside the machine, measure the voltage of battery group, check running of fans, and inspect and adjust system parameters of UPS.

#### 4.1.4 Battery Management

This system allows the charging system to be an independent charger module with high liability and without high frequency clutter which can avoid effect of high frequency wave to battery life; avoid overheat of battery when charging, and prolong working life of battery.

User can set the battery parameter by monitoring display screen (battery management parameter shall be set by professional personal, please notify the customer service personal if user needs to change these parameters), and the system can take intelligent management for battery according to user set and actual status of battery group.

Charge mode of 660 system is three-stage charge:

Stage 1: charge 90% capacity of battery

Charge with equalizing charging voltage and maximum charging current;

Stage 2: charge the balance 10% capacity of battery

Turn to stage 2 to equalizing charge for 1 minute and floating charge for 1 minute when voltage reaches to 13.85V of every battery.

Stage 3: Maintain battery capability

Charge the battery with floating charging voltage when voltage reaches to 14.25V of every battery.

Battery group of 660 series product is shared by all modules in UPS (including charging and discharging). It can use one group of battery or several groups of battery to increase the standby time of system according to user's requirement.

**Tips:** metal objects such as ring and watch must be taken off before changing the battery. Use screwdriver with insulated handle, do not put any tool or other metal object on the battery. It is normal phenomenon to appear small spark at joint when connecting the battery, but it will not cause any harm to personal safety and UPS. Do not cause short circuit or reverse connection on positive and negative of battery.

## 4.2 Trouble shooting

Faults of UPS can be known by inquiring history records of UPS, and common problems during operation of UPS can be solved by contrasting table 4.1.

**Table 4.1 Fault/warn Removal**

<b>Problem Type</b>	<b>Fault/warning</b>	<b>Solution</b>
Warning of charger module	BAT OVERCHARGED	Power off the charger and contact customer service personal.
	BAT DISCONNECTED	1. Check whether the external battery breaker is closed 2. Check whether the battery connection is normal or not
	CHARGER abnormality	Power off the charger and contact customer service personal
	CHARGER OFF	Check whether charger is started or not
	CAN communication is abnormal	Check whether the connecting line of corresponding charger module is connected well
	Disconnect the monitoring module	1. If the monitoring module is connected, please check whether the connecting line of monitoring module is connected well 2. Please insert monitoring module if the monitoring module is not connected.
	LCD ERRORVOLTSET	Contact customer service personal to change the set.
	LCD ERRORCURRSET	Contact customer service personal to change the set.
	EPO ACTIVE	Check whether button of EPO is pressed or not, please check whether the screw in left side is fastened if it is not pressed.
	CHG FANLOCK	Please contact customer service personal if the charger fan is damaged
	LINE PHASEERR	Check whether the phase sequence of three-phase input line is correct or not
Fault of charger module	NLOSS	1. Check the back terminal of module is in normal or not. 2. Check whether the terminal connected cabinet and module is in normal.
	BUS OVER	1. Check whether three-phase normal power is in balance. 2. Check whether the fluctuation of three-phase normal power is in normal.
	BUS UNDER	
	BUS UNBALANCE	
	BUS SHORT	Contact customer service personal
	BUS SOFTTIMEOUT	Pull out the module and insert it after 1 minute, and then start the machine. Please contact the customer service personal if it still not be powered on.
	BUCK SOFTTIMEOUT	
	OVER TEMPERATURE	Power off the charger, and contact the customer service personal
	LINE SCRFAIL	
	Short circuit of charger	1. Check connecting terminal of charger is short circuit or not; 2. Check port terminal of cabinet is short circuit or not.
	BAT REVERSE	Check whether the battery connection is correct and correct it
CHG IDERROR	Check whether the set of dial switch in connecting panel of	

		module of cabinet is 15 or 14. Please check dial codes of these two chargers are conflict or not if two chargers are used.
Fault of power module	BUS VOLT HIGH	1. Check whether three-phase normal power is in balance. 2. Check whether the fluctuation of three-phase normal power is in normal.
	BUS VOLT LOW	
	BUS IMBALANCE	
	BUS SHORT	Contact the customer service personal
	BUS SOFTSTART FAIL	Cut off the input breaker, and start the machine after 30s. If fault occurred on single module, please take out the module and then insert again after 30s. Please contact the customer service personal if problem still exists.
	INV SOFTSTART FAIL	
	INVERTER VOLT HIGH	Contact the customer service personal
	INVERTER VOLT LOW	
	RPHASE O/P SHORT	1. Check whether the output connection is short circuit or not.  2. Check whether the load is short circuit or not.
	SPHASE O/P SHORT	
	TPHASE O/P SHORT	
	RSPHASE O/P SHORT	
	STPHASE O/P SHORT	
	TRPHASE O/P SHORT	Please contact the customer service personal.
	R REACTIVE ABNORMAL	
	S REACTIVE ABNORMAL	
	T REACTIVE ABNORMAL	1. Power off secondary load 2. Reallocate the load so that outputs of three phases are balance. 3. Cut off UPS input breaker for 30s, then start again.
	OVERLOAD	
	OVERTEMP FAULT	Ensure environmental temperature is within working range of UPS. Cut off the UPS for 30s, and then start again.
	REALY STICK DEATH	Please contact the customer service personal.
LINE SCR FAULT		
CAN BUS FAULT	Check whether the communication line is connected well or not.	
TOTALREACTIVE FAULT	Please contact the customer service personal.	
ID ERROR	1. Check whether set of dial switch in back of module is 1~8. 2. Check whether set of dial codes in back of module is conflict.	
	LINE PHASE ERR	Check whether the three-phase input lines are connected correctly.
	BYP PHASE ERR	
	PHASE ERROR	
	PHASE LOSS	1. Check whether the input power

Other warning	BYPASS FAIL	is normal. 2. Check whether the three-phase input lines are connected.
	BPS FREQ ERR	Check whether the input power is normal.
	N LOSS	1. Check whether the back terminal of module is normal. 2. Check whether the terminal connected cabinet and module is normal.
	INPUT CB OPEN	Check whether the input breaker is closed or not.
	OUTPUT CB OPEN	Check whether the output breaker is closed or not.
	OUTPUT OVERVOLT	Please contact the customer service personal.
	MAIN CB CLOSED	Unnecessary for treatment under maintenance bypass mode
	CB COVER OPEN	1. Unnecessary for treatment under maintenance bypass mode. 2. Check whether the screw of maintenance cover is fastened or not under other working mode.
	BATVOLTLOW	1. Check whether the battery and charger are normal or not. 2. Check whether the battery set matches with actual configuration. 3. Please dismantle the secondary load as soon as possible if it is under battery mode.
	BATTERY OPEN	1. Check external battery breaker is closed or not 2. Check whether the battery is connected well
	OVLOAD FAIL	1. Close the secondary load 2. Reallocate the load so that outputs of three phases are balance.
	OVER CURRENT	
	OVER LOAD	
	REDUN OVLOAD	
	EEPROM FAIL	Forbidden to power on, and contact the customer service personal.
	FAN LOCK	Contact the customer service personal if it is module fault.
	EPO ACTIVE	Confirm whether the button of EPO is pressed or not. Please check the screw in left side of module is fastened or not if it is not pressed.
	CHARGER OFFLINE	1. Check whether the charger is inserted. 2. Insert and extract the charger module again to ensure the screw in left side of charger module is locked tightly.
	CAN FAIL	Check whether the communication line is connected well or not
	COMMSYNSIG FAIL	
COMMSYNPULSE FAIL		
ID ERROR	Check whether the set of dial switch in connecting panel in corresponding module location of cabinet is correct or not.	
MODULE ID ERROR		

### 4.3 Maintenance Assurance

Under condition of complying rules of storage, mounting, using, and operation, we have liability to debug, repair or change elements and components timely free of charge if the product is damaged due to poor quality or improper option or cannot operate normally within one year since it is delivered; we have responsibility to provide maintenance with compensation for the product if it is out of the warranty period.

Service commitment of our company is: warranted for one year and maintained for all life.

The following cases are not included in warranty range:

1. Artificial fault;
2. Out of warranty period;
3. Product whose production serial number is changed or lost;
4. Damage or loss caused by force majeure and external causes;
5. Dismantle or change the UPS without authorization;
6. Breach operation/application stipulations of the machine;
7. The battery is discharged deeply or damaged by manual.

### 4.4 Technical Specifications

Item	80KVA	160KVA	200KVA	400KVA
Cabinet capacity	20KVA-80KVA	20KVA-160KV	20KVA-200KVA	20KVA-400KVA
Max power module number	4	8	10	20
Module capacity	20KVA/16KW , 20KVA/20KW			
Input				
Rated input voltage	360/380/400/415 Vac			
Bank of input voltage	204~520Vac, load≤50%			
	242~520Vac, 50%<load≤70%			
	277~520Vac, 70%<load≤100%			
Input module	Three-phase five-wire system			
Rated frequency	50Hz/60Hz auto-adapt			
Bank of input frequency	40 ~ 70 Hz			
Input PFC	≥0.99			
Bank of bypass voltage	-40% to +20%(settable)			
Output				
Output module	Three-phase five-wire system			
Rated voltage	360/380/400/415 Vac			
Output frequency	Mains input: track bypass input in-phase; Battery input: 50Hz/60Hz			
Output PFC	0.8			
Frequency track speed	≤1 Hz/s			

Item	80KVA	160KVA	200KVA	400KVA
Inverter overload capacity	110%<load≤130%, switch to bypass in 10min; 130%<load≤150%, switch to bypass in 1min; load>150%, switch to bypass in 0.5s;			
Bypass overload capacity	≤150%, working for long time; >150%, turn off in 10s			
Switching time	0 ms			
System				
Efficiency	≥93%			
Pieces of battery	12V 40 pieces (positive and negative two group of battery,eachgroup20pieces; support 32;also support 32、34、36、38 pieces battery)			
Maximum charging current	30A (up most to 60A)		60A (up most to 120A)	
Working temperature range	0~40℃			
Working elevation height	<1500 m (Shall be reduced using if exceeding this height)			
Working relative humidity	0 ~ 95 %			
Storage temperature	-25 ~ 55℃			
Noise in 1m from surface	<60dB			
UPS cabinet size (width×deep×height) (mm)	600×1000×1600	600×1000×2000		1200×1000×2000
UPS module size (width×deep×height)(mm)	482×590×131			
UPS cabinet weight(empty)	225Kg	290Kg	280Kg	560KG
Module weight	28KG (power module) , 27KG (charger module) , 7KG (monitor module)			
Color	Black			
Monitoring module panel	5.7 inch multifunctional LCD touch wide screen			
Audible alarm	Alarm of battery mode; warn when voltage of battery is too low; alarm of fan fault, etc.			
port	USB,RS232、RS485 and dry contact			
Optional management device	SNMP card, battery temperature compensate			



## Appendix 1: Lamp Signal Reference List

Mode	Fault/warning	Status of LED	Status of buzzer
Standby mode	Phase sequence is error, and bypass is abnormal	The fault light twinkles once 2s and lasts for 1/4s	Buzz once 2s and last for 1/4s
	Battery disconnected	The fault light twinkles once 4s and lasts for 1/4s	Buzz once 4s and last for 1/4s
	No fault	All is off	No sound
Bypass mode	Some module is under fault mode	The fault light twinkles once 1s and lasts for 1/4s	Buzz once 1s and last for 1/4s
	Charger is not started	The fault light twinkles once 8s and lasts for 1/4s	Buzz once 8s and last for 1/4s
	Overload	The fault light twinkles once 2s and lasts for 1/4s	Buzz once 2s and last for 1/4s
	Phase sequence is error	The fault light twinkles once 2s and lasts for 1/4s	Buzz once 2s and last for 1/4s
	Battery disconnected	The fault light twinkles once 4s and lasts for 1/4s	Buzz once 4s and last for 1/4s
	Bypass is normal	The fault light twinkles once 4s and lasts for 1/4s	Buzz once 4s and last for 1/4s
	No other fault	The fault light twinkles once 2m and lasts for 1/4s	Buzz once 2m and last for 1/4s
Line module	Some module is under fault mode	The fault light twinkles once 1s and lasts for 1/4s	Buzz once 1s and last for 1/4s
	Charger is not started	Normal light is on, fault light twinkles once 8s and lasts for 1/4s	Buzz once 8s and last for 1/4s
	Overload	Normal light is on, fault light twinkles once 2s and lasts for 1/4s	Buzz once 2s and last for 1/4s
	Battery disconnected	Normal light is on, fault light twinkles once 4s and lasts for 1/4s	Buzz once 4s and last for 1/4s
	No other fault	Normal light is on	No sound
Battery self-test	Some module is under fault mode	Fault light is on all the time	Buzz all the time
	Low-voltage of battery	Battery light twinkles once 1s	Buzz once 1s and last for 1/4s
	Overload	All is off	Buzz once 2s and last for 1/4s
	Others are normal	Twinkle in turn for every 2s	No sound
Fault mode	Bypass and output are normal	Bypass light is on, fault light is on all the time	Buzz all the time
	Bypass and output are abnormal	Fault light is on all the time	Buzz all the time
Frequency conversion mode	Some module is under fault mode	Normal light is on, fault light twinkles once 1m and lasts for 1/4s	Buzz once 1m and last for 1/4s
	No fault	Normal light is on	No sound
Power off		All is off	No sound
Communication is abnormal		All is off	No sound

## Appendix 2: Port of Communication Interface

There are several communication ports for 660 system, as shown in figure 1:

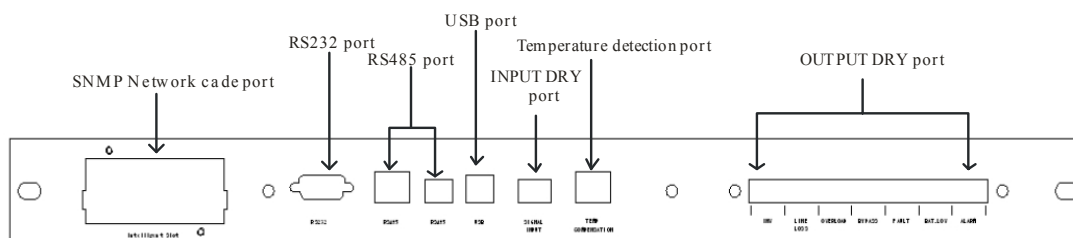

Figure 1 Chart of 660 Communication Port

### 1. SNMP Network Card Port (optional fitting)

The LAN port communication needs to be set as:

Connect the computer and system with network cable. It can use twisted pair network cable to connect the computer directly or use direct network cable to connect the computer through switchboard.

### 2. RS232 Port

Its maximum transmission range is 50m when the baud rate is 9600.

RS232 interface definition (others are not connected):

Stitch	2	3	5
definition	RXD	TXD	GND

### 3. RS485 Port

Its maximum transmission range is 500m when the baud rate is 9600.

RS485 provides different ports for two kinds of connecting modes, one is RJ45 network cable port, and the other is double-pin port.

RJ45 network port (others are not connected):

Stitch	1、2、	4、5
definition	A	B

Double-pin port:

Stitch	1	2
definition	A	B

#### 4. USB Port

The USB port is special port for UPSmart2000I monitoring software.

#### 5. Inspection Port of Battery Temperature

The charger module can collect battery temperature at any time to provide temperature compensation through inspection port of battery temperature.

#### 6. Passive Output Dry Contact

660 modularized UPS is equipped with a dry contact card which contains 7 groups of independent passive output dry contacts with three connecting terminals for every dry contact. From left to right which are: normally closed terminal, common terminal, and normally open terminal. The passive dry contact is controlled by relay, and the common terminal and normally closed terminal of relay will be connected when defined status of dry contact is false; the relay will start operation at once when defined status of dry contact is true, and the common terminal will be disconnected with normally closed terminal of relay, and be connected with normally open terminal. User can select to connect the normally open terminal or normally closed terminal according to actual demand.

Identifier	Meaning
INV	Inverter output
BYPASS	Bypass output
LINE LOSS	Mains power is abnormal
OVER LOAD	Overload of output
FAULT	System fault
BAT.LOW	Warning of battery low-voltage
ALARM	System alarm

## 7. Input Dry Contact

660 modularized UPS is equipped with a set of dry contact interface "SIGNAL INPUT". It's a 3 PIN interface. From left to right the 3 PIN separately defined as: Ground, dry contact 2 and dry contact 1 in frontispiece view. Dry contact 2 realizes the function of emergency turning off, PIN 1 and PIN 2 are normally close. When PIN1 and PIN 2 open, the UPS turn off immediately. Dry contact 1 use to realize Battery breaker which is opening or closing. And Dry contact 1 also use to realize dynamotor which is inputting or opening.

Input Dry Contact	DRY1	dynamotor	PIN1 ,PIN3 closed	Dynamotor
			PIN1 ,PIN3 opened	Normally
		Battery breaker	PIN1 ,PIN3 closed	Battery breaker closed
			PIN1 ,PIN3 opened	Battery breaker opened
	DRY2	EPO	PIN1 ,PIN2 closed	Normally
			PIN1 ,PIN2 opened	EPO( Distance emergency power off)